

Digital Video Camera Module

Technical Manual

XCL-U1000C/U1000

Table of Contents

Overview

Features	3
System Components	5
Connection Diagram	5
Location and Function of Parts and Controls	6
Front/Top/Bottom	6
Rear	7
Connecting the cables	8

Functions of the XCL-U1000C/U1000

About the Camera Modes	10
■ Normal Mode	10
■ Trigger Mode	11
■ Binning Mode (XCL-U1000 only)	12
■ Binning Mode with external trigger (XCL-U1000 only) ..	12
■ High rate scan Mode	13
■ High rate scan Mode with external trigger	15

Camera Control Command

Overview	16
Serial Communication Specifications	16
Command System	16
Command Format	16
Command Input and Response	16
Command Specifications	17
Camera Control Commands	17
Setting Value Control Commands	21
Other Commands	23
Command List	24

Specifications

Specifications	25
Spectral Sensitivity Characteristics (Typical Values)	26
XCL-U1000C/U1000 Dimensions	27

Overview

The XCL-U1000C/U1000 is a digital video camera module. This camera module outputs digital images utilizing LVDS via the digital interface connector.

- XCL-U1000C: Color digital camera module
- XCL-U1000: Monochrome digital camera module

Features

Digital interface connector

Equipped with a small size digital interface connector. The XCL-U1000C/U1000 can output a digital image at 15 frames per second.

High image quality

The XCL-U1000C/U1000 (UXGA) has a progressive scan CCD of 2,000,000 pixels. This camera produces high-resolution images. By adopting square pixels, images can be processed using the original aspect ratio without a converting procedure.

Various mode settings

Sending a command from the host device allows the following mode settings.

- Gain
- Read mode: normal /binning
- High rate scan
- Shutter: Normal/Trigger shutter
- Shutter speed
- Gamma
- Detail
- White balance (XCL-U1000C only)
- Matrix (XCL-U1000C only)

Electronic shutter function

Shutter speed can be selected from a wide range.

External trigger shutter function (1/15 to 1/10000 sec.)

You can obtain a freeze picture by inputting an external trigger. This function is useful to shoot a fast-moving object clearly.

High rate scan

The camera module can limit the number of effective video output lines to achieve high frame rates, enabling high-speed image processing.

Binning (XCL-U1000 only)

By “binning” two pixels that align vertically, you can acquire a frame rate twice as high as that in the normal mode.

Matrix (XCL-U1000C only)

Utilizing the matrix unit reproduces color more accurately.

White balance (XCL-U1000C only)

White balance can be set to any of the following modes.

- Preset: 3200K/5600K/6500K
- Manual
- AWB (Automatic White Balance)

To execute the AWB, put a white object on the center of the screen. Be sure it appears to be more than one third of the entire screen space.

Detail

The camera module can accentuate all the edges of an image producing sharper detail.

Body fixing

The screw holes to install the camera module are located under the front panel (the CCD reference plane). Installing the camera module on the front panel minimizes deviation of the optical axis.

Note

The CCD is driven at high speed during a High rate scan or Binning operation. In this situation, if intense light is input to the camera, the peripheral areas of the video image may be affected. In such a situation, adjust the amount of light using the iris.

System Components

Video camera module
XCL-U1000C/U1000

Camera cables
CCXC-12P02N(2 m)
CCXC-12P05N(5 m)
CCXC-12P10N(10 m)
CCXC-12P25N(25 m)

Camera adaptor
DC-700/700CE

Tripod adaptor
VCT-ST70I
(Insulated type)

C-mount lens
High-resolution lens

Close-up ring kit
LO-77ERK

Digital interface-compatible interface board (commercially available)
Insert this to the PCI bus slot of the host device such as a PC.

Camera module interface board

Digital interface cable
1MA26-4560-OSC-200 (2 m, 6.6 ft)
500 (5 m, 16.4 ft)
A00 (10 m, 32.8 ft)

Sony camera-compatible cable produced by Sumitomo 3M Limited (commercially available)

Connection Diagram

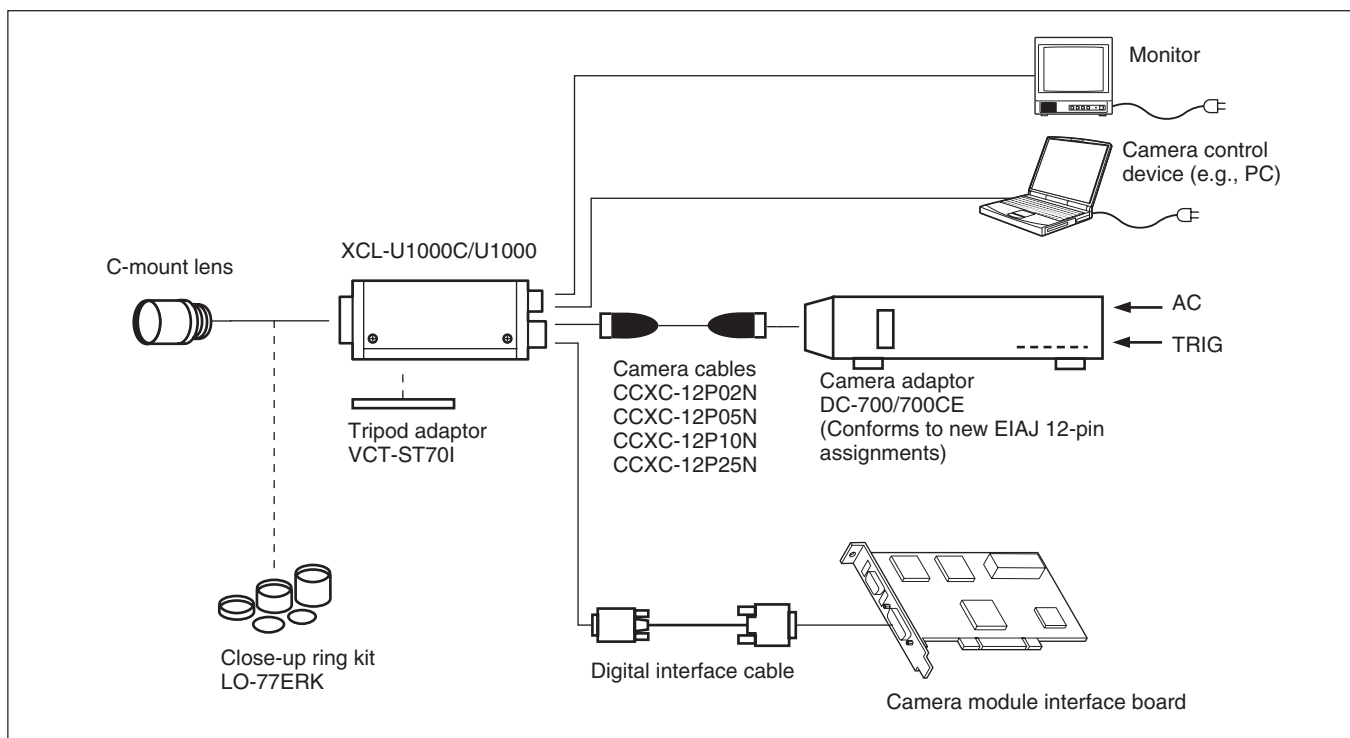

Location and Function of Parts and Controls

Front/Top/Bottom

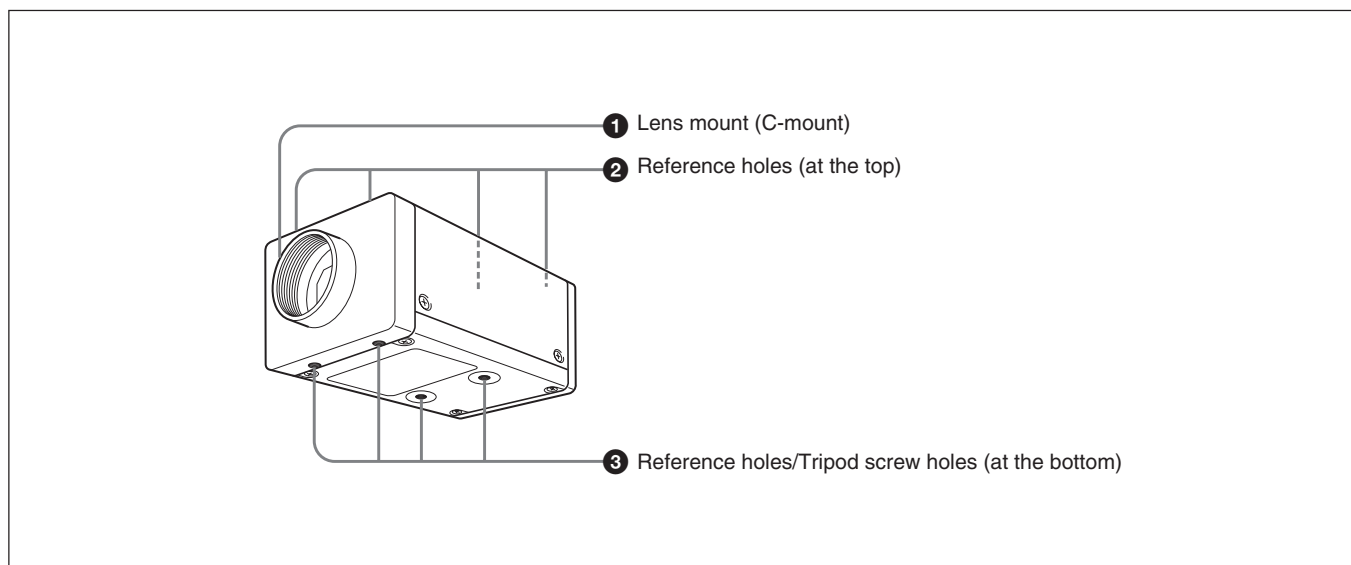

❶ Lens mount (C-mount)

Attach any C-mount lens or other optical equipment.

Note

The lens must not project more than 7 mm (9/32 inch) from the lens mount.

❷ Reference holes (at the top)

❸ Reference holes/Tripod screw holes (at the bottom)

These precision screw holes are for locking the camera module. Locking the camera module into these holes secures the optical axis alignment.

You can install the camera on a tripod. To install on a tripod, you will need to install a tripod adaptor VCT-ST70I to the camera on the reference holes ❸.

Rear

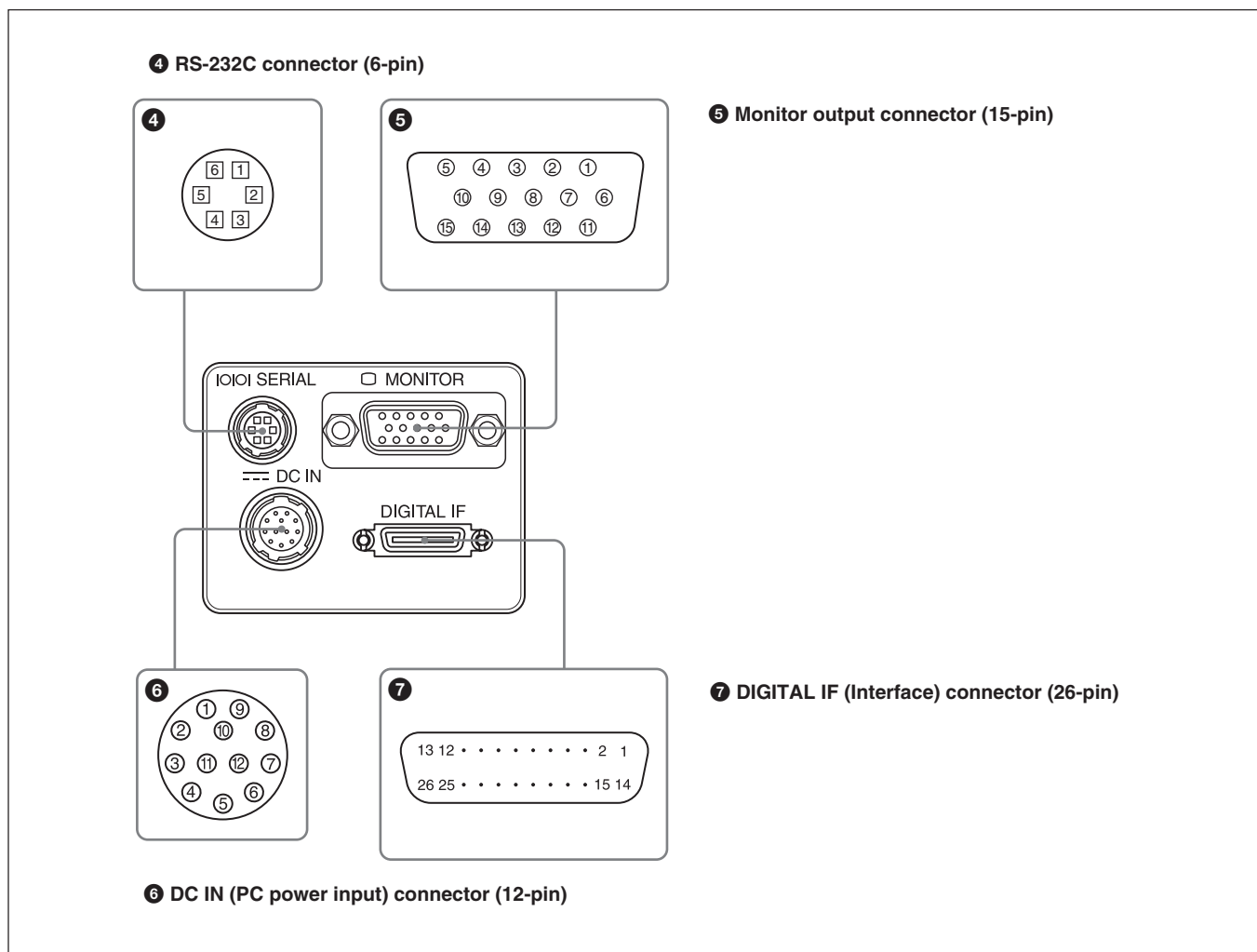

4 RS-232C connector (6-pin)

You can connect a serial cable to this connector to control a camera module from a camera control device (e.g., PC).

Pin No.	Signal	Pin No.	Signal
1	TXD	4	NC
2	RXD	5	NC
3	Ground	6	NC

5 Monitor output connector (15-pin)

You can connect a monitor cable to this connector to display an image on a multiscan monitor supporting UXGA resolution.

Note

If you connect a multiscan monitor that does not support UXGA resolution, an image may not be displayed.

Pin No.	Signal	Pin No.	Signal
1	R output	9	NC
2	G output	10	Ground
3	B output	11	NC
4	NC	12	NC
5	Ground	13	HD output
6	Ground	14	VD output
7	Ground	15	NC
8	Ground		

6 DC IN (DC power input) connector (12-pin)

You can connect a CCXC-12P05N camera cable to input the +12 V DC power supply. The pin configuration of this connector is as follows.

Pin No.	Signal	Pin No.	Signal
1	Ground	7	NC
2	+12 V DC	8	Ground
3	Ground	9	NC
4	NC	10	Exposure pulse output
5	Ground	11	Trigger pulse input
6	NC	12	Ground

7 DIGITAL IF (Interface) connector (26-pin)

You can connect a digital interface cable to this connector to control a camera module from a host device utilizing the serial communication protocol while outputting a video signal from the camera module. You can input the external trigger signal via the 26-pin connector and operate a camera module in the external trigger mode. The pin configuration of this connector is as follows.

Pin No.	Digital signal	Pin No.	Digital signal
1	INNER_SHIELD (Ground)	14	INNER_SHIELD (Ground)
2	X0- output (Signal)	15	X0+ output (Signal)
3	X1- output (Signal)	16	X1+ output (Signal)
4	X2- output (Signal)	17	X2+ output (Signal)
5	XCLK- output (Signal)	18	XCLK+ output (Signal)
6	X3- output (Signal)	19	X3+ output (Signal)
7	Ser TC+ (Signal)	20	Ser TC- (Signal)
8	Ser TFG- (Signal)	21	Ser TFG+ (Signal)
9	TRIG- input (Signal)	22	TRIG+ input (Signal)
10	NC	23	NC
11	NC	24	NC
12	NC	25	NC
13	INNER_SHIELD (Ground)	26	INNER_SHIELD (Ground)

Note

When you operate a camera module by inputting an external trigger signal via the 26-pin connector, make sure to input external trigger signals that meet the following specifications to both the two pins.

Specifications for the External Trigger Signal
 Amplitude: LVDS using a 3.3 volt IC Polarity: positive



Connections: Input a TRIG (-) signal to the 9th pin.
 Input a TRIG (+) signal to the 22nd pin.

Connecting the cables

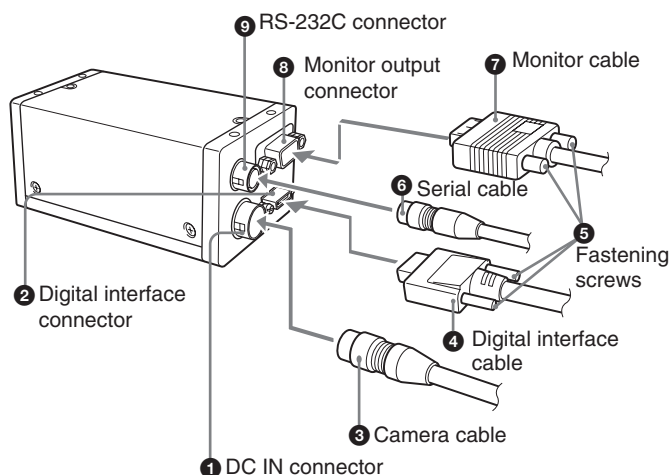

Connect the camera cable to the DC IN connector and the digital interface cable to the digital interface cable respectively. Also, if needed, connect the monitor cable to the monitor output connector and the serial cable to the RS-232C connector respectively. When you connect the digital interface cable or monitor cable, turn the two fastening screws on the connector to secure the cable tightly.

Connect the other end of the camera cable to the DC-700/700CE and the other end of the digital interface cable to the camera module interface board. Also, if needed, connect the other end of the monitor cable to the monitor and the other end of the serial cable to the camera control device.

About the camera control method

You can control the camera from host device such as a PC. The following table shows the control functions. You can send a command corresponding to the control items, with parameters for the desired settings, if necessary, from the host device to control the camera. Refer to “Camera Control Command” on page 16 for details on how to send a command, the commands, and their parameters.

Control functions	Description	
Operating mode	Normal/Trigger	
Shutter speed	Normal	1 – $1/10000$
	Trigger	Internal setting: $1/15$ – $1/10000$
		Setting by trigger pulse width
Gain	0 to +18 dB	
Binning function	OFF/ON	
Partial Scan function	OFF/ON	
Detail	OFF/ON	
External trigger input	26-pin connector / DC-700 / 700CE	
White balance (XCL-U1000C only)	Preset/Manual/AWB	
Matrix (XCL-U1000C only)	OFF/ON	

Note

Make sure to supply power to the camera module and confirm that the camera module is operating before inputting a trigger signal. If you input external signals to a camera module without the power supplied, this may cause a malfunction of the camera module.

Functions of the XCL-U1000C/U1000

About the Camera Modes

■ Normal Mode

Description: Outputs each independent pixel video signal for 1/14.976 second.

Application: Use this mode to provide continuous standard video output.

Vertical timing

1V=1252H

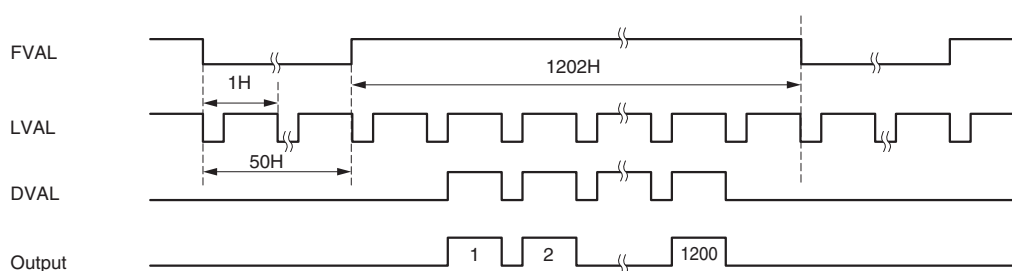

Horizontal timing

1H=1920CL

1CL=1/36 MHz=27.8 ns

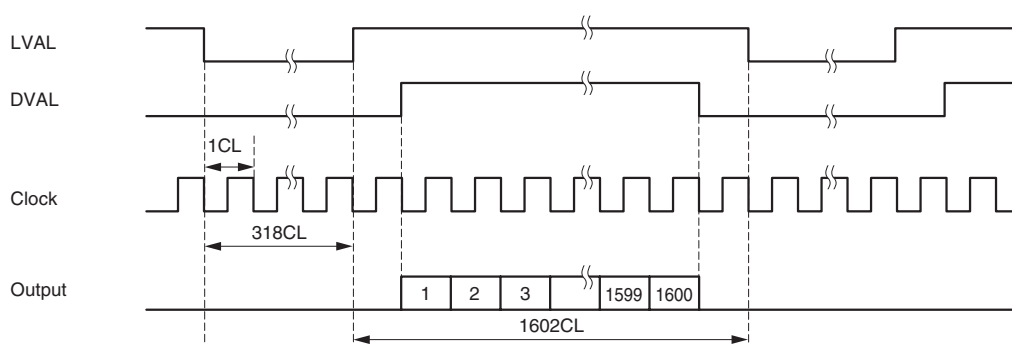

■ Trigger Mode

Description: Starts accumulation in synchronization with an input of external trigger signals and outputs each independent video signal after a certain period of time. An electronic shutter function enables you to capture fast moving subjects in sharp focus.

Two trigger modes are available.

- Edge detection mode

Set the trigger mode to OFF and select a shutter speed. Then set the edge detection mode.

Shutter speed can be set to any of the followings:

1/15, 1/30, 1/100, 1/120, 1/250, 1/500, 1/1000, 1/2000, 1/5000, and 1/10000 s

- Pulse width detection mode

Set both the trigger mode and the shutter speed to OFF. Then set the pulse detection mode. The accumulation time becomes a trigger pulse width.

Application: Use this mode to obtain a video signal synchronized with an input of external trigger signals after a certain period of time.

Vertical timing

(Horizontal timing is the same as Normal mode.)

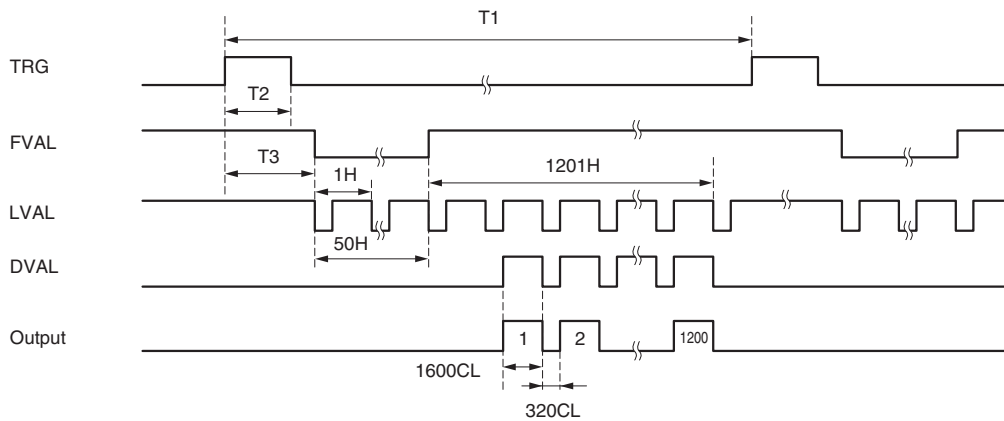

High rate scan mode=OFF
Binning mode=OFF

Trigger mode	T1	T2	Shutter	T3 [ms]
Edge detection	67 ms or more	100 us or more, 1 s less than	1/15 s	70.68
			1/30 s	37.40
			1/100 s	14.04
			1/120 s	12.40
			1/250 s	8.08
			1/500 s	6.06
			1/1000 s	5.08
			1/2000 s	4.53
			1/5000 s	4.28
1/10000 s	4.17			
Puls width detection	67 ms or more	100 us or more, 1 s less than	66.7 ms	70.82
			33.3 ms	37.34
			10.0 ms	14.02
			8.33 ms	12.33
			4 ms	8.03
			1 ms	6.03
			100 us	4.13
			OFF	

■ Binning Mode (XCL-U1000 only)

By adding two more vertical lines when reading out from a CCD, you can acquire a frame rate twice as high as that in the normal mode. If a shutter speed is

set, set the binning mode to ON to double the sensitivity.

Vertical timing 1V=626H (Horizontal timing is the same as Normal mode.)

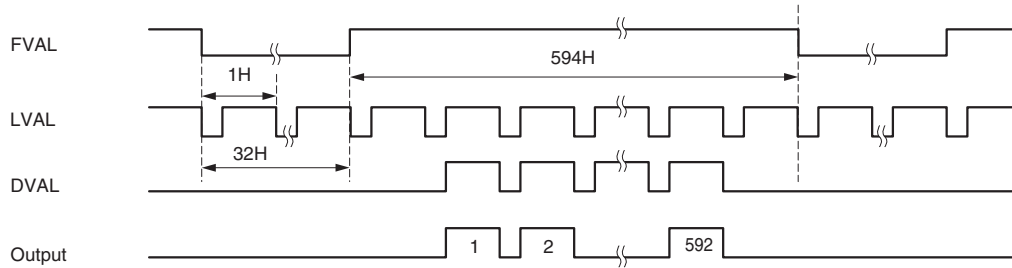

■ Binning Mode with external trigger (XCL-U1000 only)

Vertical timing (Horizontal timing is the same as Normal mode.)

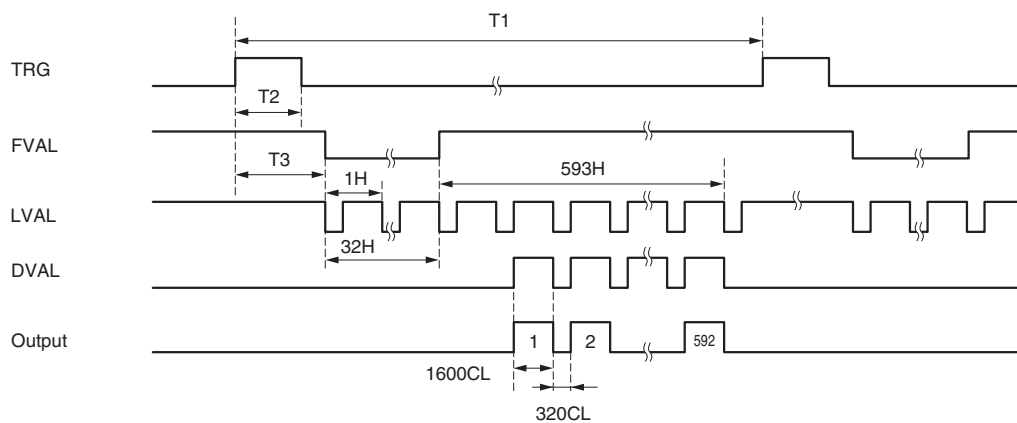

Trigger mode	T1	T2	Shutter*1	T3 [ms]
Edge detection	33.5 ms or more	100 us or more, 1 s less than	1/30 s	37.40
			1/100 s	14.04
			1/120 s	12.40
			1/250 s	8.08
			1/500 s	6.06
			1/1000 s	5.08
			1/2000 s	4.53
			1/5000 s	4.28
Puls width detection	33.5 ms or more	100 us or more, 1 s less than	OFF	4.17
			66.7 ms	70.82
			33.3 ms	37.34
			10.0 ms	14.02
			8.33 ms	12.33
			4 ms	8.03
			1 ms	6.03
100 us	4.13			

*1 In the edge detection mode, you cannot set a shutter speed slower than 1/15 s.

High rate scan Mode

You can divide the effective image interval vertically into 16 sections and select arbitrary sections as the effective image. You can transfer less critical parts at

high frame rates and obtain image output at high frame rates. Set the start position and end position to use the function.

Vertical timing

(Horizontal timing is the same as Normal mode.)

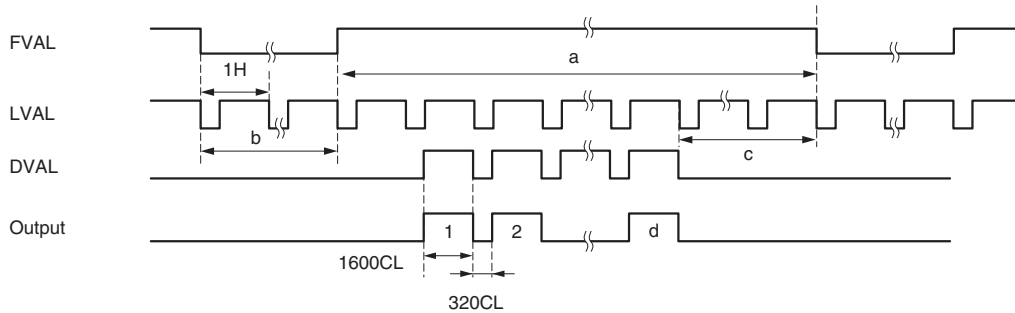

Start	End	a[H]	b[H]	c[H]	d[H]	rate[fps]
0	1	190	36	125	64	83
	2	257	36	112	144	64
	3	325	36	108	216	52
	4	392	36	103	288	44
	5	460	36	91	368	38
	6	527	36	86	440	33
	7	595	36	82	512	30
	8	662	36	69	592	27
	9	730	36	65	664	24
	10	797	36	52	744	23
	11	865	36	48	816	21
	12	932	36	43	888	19
	13	1000	36	31	968	18
	14	1067	36	26	1040	17
	15	1135	36	22	1112	16
1	2	182	44	117	64	83
	3	249	44	104	144	64
	4	317	44	100	216	52
	5	384	44	95	288	44
	6	452	44	83	368	38
	7	519	44	78	440	33
	8	587	44	74	512	30
	9	654	44	61	592	27
	10	722	44	57	664	24
	11	789	44	44	744	23
	12	857	44	40	816	21
	13	924	44	35	888	19
	14	992	44	23	968	18
	15	1059	44	18	1040	17
	16	1127	44	14	1112	16
	2	3	173	53	108	64
4		240	53	95	144	64
5		308	53	91	216	52
6		375	53	86	288	44
7		443	53	74	368	38
8		510	53	69	440	33
9		578	53	65	512	30
10		645	53	52	592	27
11		713	53	48	664	24
12		780	53	35	744	23
13		848	53	31	816	21
14		915	53	26	888	19
15		983	53	14	968	18
16		1048	53	7	1040	17

Start	End	a[H]	b[H]	c[H]	d[H]	rate[fps]	
3	4	166	60	101	64	83	
	5	233	60	88	144	64	
	6	301	60	84	216	52	
	7	368	60	79	288	44	
	8	436	60	67	368	38	
	9	503	60	62	440	33	
	10	571	60	58	512	30	
	11	638	60	45	592	27	
	12	706	60	41	664	24	
	13	773	60	28	744	23	
	14	841	60	24	816	21	
	15	908	60	19	888	19	
	16	976	60	7	968	18	
	4	5	158	68	93	64	83
		6	225	68	80	144	64
		7	293	68	76	216	52
8		360	68	71	288	44	
9		428	68	59	368	38	
10		495	68	54	440	33	
11		563	68	50	512	30	
12		630	68	37	592	27	
13		698	68	33	664	24	
14		765	68	20	744	23	
15		833	68	16	816	21	
16		898	68	9	888	19	
5		6	151	75	86	64	83
		7	213	75	68	144	65
		8	286	75	69	216	52
		9	353	75	64	288	44
	10	421	75	52	368	38	
	11	488	75	47	440	33	
	12	556	75	43	512	30	
	13	623	75	30	592	27	
	14	691	75	26	664	24	
	15	758	75	13	744	23	
	16	826	75	9	816	21	

Start	End	a[H]	b[H]	c[H]	d[H]	rate[fps]
6	7	143	83	78	64	83
	8	210	83	65	144	64
	9	278	83	61	216	52
	10	345	83	56	288	44
	11	413	83	44	368	38
	12	480	83	39	440	33
	13	548	83	35	512	30
	14	615	83	22	592	27
	15	683	83	18	664	24
16	748	83	3	744	23	
7	8	136	90	71	64	83
	9	203	90	58	144	64
	10	271	90	54	216	52
	11	338	90	49	288	44
	12	406	90	37	368	38
	13	473	90	32	440	33
	14	541	90	28	512	30
	15	608	90	15	592	27
16	676	90	11	664	24	
8	9	128	98	63	64	83
	10	195	98	50	144	64
	11	263	98	46	216	52
	12	330	98	41	288	44
	13	398	98	29	368	38
	14	465	98	24	440	33
	15	533	98	20	512	30
16	598	98	5	592	27	
9	10	121	105	56	64	83
	11	188	105	43	144	64
	12	256	105	39	216	52
	13	323	105	34	288	44
	14	391	105	22	368	38
	15	458	105	17	440	33
16	526	105	13	512	30	
10	11	113	113	48	64	83
	12	180	113	35	144	64
	13	248	113	31	216	52
	14	315	113	26	288	44
	15	383	113	14	368	38
16	448	113	7	440	33	

Start	End	a[H]	b[H]	c[H]	d[H]	rate[fps]
11	12	106	120	41	64	83
	13	173	120	28	144	64
	14	241	120	24	216	52
	15	308	120	19	288	44
	16	376	120	7	368	38
12	13	98	128	33	64	83
	14	165	128	20	144	64
	15	233	128	16	216	52
	16	298	128	9	288	44
13	14	91	135	26	64	83
	15	158	135	13	144	64
	16	226	135	9	216	52
14	15	83	143	18	64	83
	16	148	143	3	144	64
15	16	76	150	11	64	83

High rate scan Mode with external trigger

Vertical timing

(Horizontal timing is the same as Normal mode.)

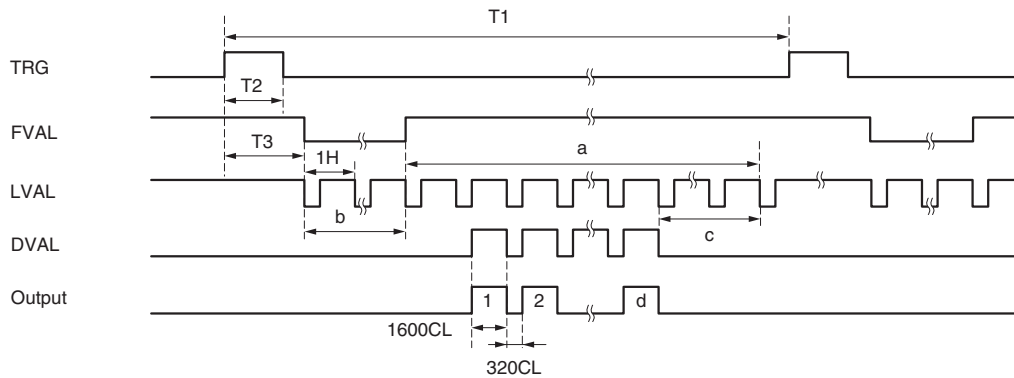

Trigger mode	T1*1	T2	Shutter*2	T3 [ms]
Edge detection	See the formula on the right.	100 us or more, 1 s less than	1/30 s	37.40
			1/100 s	14.04
			1/120 s	12.40
			1/250 s	8.08
			1/500 s	6.06
			1/1000 s	5.08
			1/2000 s	4.53
			1/5000 s	4.28
Puls width detection	See the formula on the right.	100 us or more, 1 s less than	66.7 ms	70.82
			33.3 ms	37.34
			10.0 ms	14.02
			8.33 ms	12.33
			4 ms	8.03
			1 ms	6.03
			100 us	4.13

*1 Set a trigger cycle (1/T1) using the following formula.

$$T1 > 1920(a+b)/36000 + 0.1[\text{ms}]$$

Refer to the table of the high rate scan mode (no external trigger) for the values of "a," "b," "c," and "d."

*2 In the edge detection mode, you cannot set a shutter speed slower than 1/15 s. If the rate is over 30 fps, you cannot set a shutter speed to 1/30 s. Set a rate referring to the table of the high rate scan mode (no external trigger).

Camera Control Command

Overview

The XCL-U1000C/U1000 can be controlled externally from a host device via a serial communication using such communication softwares as “HyperTerminal” or “Tera Term.”

Serial Communication Specifications

The serial communication system for the XCL-U1000C/U1000 is an asynchronous method compliant with RS-232C. The following table shows the transmission control specifications.

Command inputs are echoed back.

Baud rate	57600/38400/19200/9600/4800 [bps] Default setting: 38400 [bps]
Data bits	8
Parity	None
Stop bit	1
Flow control	None

XCL-U1000C/U1000 RS-232C connection

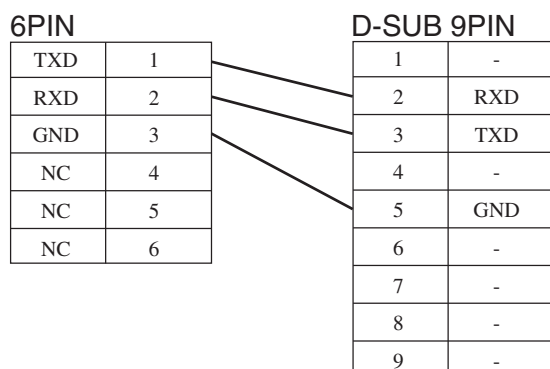

Command System

The following table shows the command system.

Command category	Description
Camera control commands	Controls the camera.
Setting value control command	Controls setting data saved in the camera.

Command Format

To input (send) a command, delimit a command name and parameters with spaces, and press the Enter (Carriage Return) key.

The following show the input format and an example:

```
<Input format>    command param1 param2 param3 [Enter]  
<Input example>  PARTIAL 1 0 15 <CR>
```

Notes

- A command name and parameters that follow cannot be omitted (except for the last parameter) .
- Input characters are non case sensitive.
- Input decimal numbers for parameters.

Command Input and Response

The camera returns an echo back to valid inputs; alphabets, numbers, “-”, spaces, backspaces and [ENTER] (Carriage Return). Input of letters and symbols other than these are all ignored.

- When command execution is completed normally, the screen displays “OK.”

```
<Input>           PARTIAL 1 0 15 <CR>  
<Output on screen> OK <CR>
```

- If command execution is terminated abnormally, the screen displays “ERROR STATUS.” Alternatively, the result is shown in details. (To be described by category.)

- When no parameter is input for a command with parameters, the screen displays the current parameters of the command.

```
<Input>          PARTIAL 1 0 15 <CR>
<Output on screen> OK <CR>
<Input>          PARTIAL <CR>
<Output on screen> 1,0,15 <CR>
```

- If an input value is out of parameter range, the command is invalid and the screen displays “ERROR SYNTAX.”

```
<Input>          PARTIAL 1 0 20 <CR>
<Output on screen> ERROR SYNTAX <CR>
```

- If an invalid command name is input, the screen displays “ERROR SYNTAX”.

```
<Input>          PART 1 0 20 <CR>
<Output on screen> ERROR SYNTAX <CR>
```

- If the Enter key is pressed with no command input, only the carriage return is carried out.

Command Specifications

This section describes the details of control commands available for the XCL-U1000C/U1000, classified by category.

Camera Control Commands

Camera control commands fall into eight categories.

Category	Description
AFE	Sets AFE modes.
Shutter/Trigger	Selects a shutter speed and a trigger mode.
WB	Adjusts white balance.
DTL	Adjusts edge enhancement.
Color	Adjusts color matrix.
Gamma	Sets γ table.
Binning/Partial	Selects a binning mode and a partial scan mode.
IN/OUT	Sets input/output of a camera.

All the parameters used in camera control commands are saved in a Flash ROM fitted with a microcomputer.

AFE Setting Commands

■ Gain-Step Setting

```
[Command]  GAIN-STEP
[Parameter1] <Gain (0 to 18)> [dB]
[Process]   Sets VGA gain value of AFE IC. The value set in “0 dB gain auto adjustment” is applied to “0 to 18 dB.”
```

■ Gain-Fine Adjustment Setting

```
[Command]  GAIN-FINE
[Parameter1] <Gain (0 to 522)>
[Process]   Divides “Gain-Step Setting” range (0 to 18 dB) into 522 portions and fine-tunes VGA gain value of AFE IC.
```

■ Pedestal Setting

```
[Command]  PEDESTAL
[Parameter1] <Pedestal level (0 to 255)>
[Process]   XCL-U1000: Sets AFE clamp level.
             XCL-U1000C: Sets DSP offset level.
```

Shutter/Trigger Setting Commands

■ Shutter Speed Setting

[Command] SHUTTER

[Parameter1] <Shutter setting (0 to 13)>

0: OFF	5: 1/250 s	10: 1/10000 s
1: 1/15 s	6: 1/500 s	11: 1/7.5 s
2: 1/30 s	7: 1/1000 s	12: 1/2 s
3: 1/100 s	8: 1/2000 s	13: 1 s
4: 1/120 s	9: 1/5000 s	

[Process] Selects a shutter speed.

■ Trigger Mode Setting

[Command] TRG-MODE

[Parameter1] <Mode (0 to 2)>

- 0: OFF
 - Outputs video in regular mode.
- 1: Starts exposure to control shutter speed when an effective external trigger edge is detected. The selection made in “Shutter Speed Setting” becomes valid.
- 2: External pulse width detection
 - Controls shutter speed by an external trigger pulse width. The selection made in “Shutter Speed Setting” becomes invalid.

[Process] Sets trigger operation mode.

■ External Trigger Pulse Polarity Setting

[Command] TRG-POL

[Parameter1] <Mode (0 to 1)>

- 0: Negative
- 1: Positive

[Process] Determines the polarity of an external trigger pulse.

WB Setting Commands (For XCL-U1000C only)

■ White Balance Mode Setting

[Command] WBMODE

[Parameter1] <Mode (0 to 4)>

- 0: 3200K preset
 - The preset data for “WB preset value(3200K)” becomes valid.
- 1: 5600K preset
 - The preset data for “WB preset value(5600K)” becomes valid.
- 2: 6500K preset
 - The preset data for “WB preset value(6500K)” becomes valid.
- 3: WB manual setting
 - The value set manually becomes valid.
- 4: One Push AWB
 - Executes “One Push AWB.” After execution, the data becomes valid.

[Process] Selects a white balance mode.

■ Manual R Gain Setting

[Command] RGAIN

[Parameter1] <Gain (0 to 0xFF)>

[Process] Sets R gain value in WB manual setting mode. The parameter is ± 128 . The camera regards the R gain value set in “WB preset value (3200K)” as the standard value (=0).

■ Manual B Gain Setting

[Command] BGAIN

[Parameter1] <Gain (0 to 0xFF)>

[Process] Sets B gain value in WB manual setting mode. The parameter is ± 128 . The camera regards the B gain value set in “WB preset value (3200K)” as the standard (=0).

■ AWB Detection Range Display

[Command] AWBWINDOW

[Parameter1] <Mode (0 to 1)>

- 0: Display OFF
- 1: Display ON

[Process] Selects whether to show or hide the detection range display.

■ One Push AWB Execution

[Command] AUTOWB

[Process] Performs “One-push AWB” when “White Balance Mode Setting: One Push AWB” is selected. This command is ignored when White Balance Mode Setting is not set to “One Push AWB.” The camera does not accept another command during an execution of command. The following message appears when the task is completed.

“AWB OK”:

Completed normally.

“LEVEL HIGH”:

Failed because the luminance level is too high.

“LEVEL LOW”:

Failed because the luminance level is too low.

“CTEMP HIGH”:

Failed because the color temperature level is too high.

“CTEMP LOW”:

Failed because the color temperature level is too low.

“TIME OUT”:

Time out.

DTL Setting Commands

- Edge Enhancement Filter Coefficient Setting

[Command] DTL-COEF

[Parameter1] <K0 setting value (0 to 0x7F)>

[Parameter2] <K1 setting value (0 to 0x7F)>

[Parameter3] <K2 setting value (0 to 0x7F)>

[Process] Sets coefficients for the edge enhancement filter. The currently set value is applied to the parameter for which no specific value is set.
- Edge Enhancement Coring Threshold Setting

[Command] DTL-TH

[Parameter1] <Negative threshold (0 to 0xFF)>

[Parameter2] <Positive threshold (0 to 0xFF)>

[Process] Sets coring thresholds for the DSP edge enhancement filter. When a value is set only for Parameter1, the same value is automatically applied to Parameter2.
- Edge Enhancement Data Scale Setting

[Command] DTL-SCL

[Parameter1] <Negative enhancement level (0 to 0x3F)>

[Parameter2] <Positive enhancement level (0 to 0x3F)>

[Process] Sets enhancement levels for the DSP edge enhancement filter. When a value is set only for Parameter1, the same value is automatically set for Parameter2.
- Edge Enhancement Data Level Setting

[Command] DTL-LVL

[Parameter1] <Lower limit of enhancement (0 to 0x3FF)>

[Parameter2] <Upper limit of enhancement (0 to 0x3FF)>

[Process] Sets enhancement limits for the DSP edge enhancement filter. When a value is set only for Parameter1, the same value is automatically set for Parameter2.
- Sharpness Setting (For XCL-U1000C only)

[Command] SHARP

[Parameter1] <Sharpness (0 to 7)>

[Process] Adjusts sharpness of the output images.
- DTL Mode Setting

[Command] DTL-MODE

[Parameter1] <Mode (0 to 1)>

0: OFF
→ DTL OFF

1: ON
→ DTL ON

[Process] Selects a DTL mode. When set to ON, all the setting values set using DTL Setting Commands becomes valid. When set to OFF, values for the edge enhancement data scale and the sharpness are automatically set to “0.”

Color Setting Commands (For XCL-U1000C only)

- Color Matrix Setting

[Command] COLORMTX

[Parameter1] <Mode (0 to 2)>

0: OFF
→ Invalidates RGB correction matrix.

1: ON
→ Validates RGB correction matrix.

2: Data setting
→ Sets matrix coefficients for Parameter1, Parameter2 and Parameter3.

[Parameter2] <Matrix element (0 to 8)>

[Parameter3] <Matrix setting value (0 to 0x3FF)>

[Process] Sets coefficients for RGB compensation matrix. The values set in Parameter2 and Parameter3 are ignored if “Parameter1: 2 (Data setting)” is not selected. The mode setting value is retained only when “0: OFF” and “1: ON” are selected.

Gamma Setting Commands

- γ Table Setting

[Command] GAMMA

[Parameter1] <Mode (0 to 3)>

0: OFF
→ $\gamma=1$

1: ON
→ Validates the user setting table.

2: Reverse
→ Reverse.

3: Binarization
→ Binalize.

[Process] Sets γ table.
- γ Binalization Threshold Setting

[Command] BINARIZE

[Parameter1] <Binalization setting value (0 to 1024)>

[Process] Sets a binalization threshold in γ table. It becomes valid only when “ γ table setting: 3 (Binarization)” is selected.

- γ Table Data Setting
 - [Command] GTBL
 - [Parameter1] <Data setting start point (0 to 1,023)>
 - [Process] Enters γ table data setting mode that allows users to input data to the table. To exit the mode, input "Q."

Binning/Partial Setting Commands

- Binning Mode Setting (For XCL-U1000 only)

[Command] BINNING
 [Parameter1] <Mode (0 to 1)>
 0: OFF
 → Binning OFF
 1: V
 → Vertical binning
 [Process] Selects a binning mode.

- Partial Scan Setting

[Command] PARTIAL
 [Parameter1] <Mode (0 to 1)>
 0: OFF
 1: ON
 [Parameter2] <Readout start position (0 to 15)>
 [Parameter3] <Readout end position (1 to 16)>
 [Process] Selects a partial scan mode using Parameter1, specify readout area of partial scan using Parameter2 and 3. If no value is set for a parameter, the currently set value for the parameter becomes valid.
 The effective partial scan range is shown below. If an input value is out of range, it becomes invalid.
 $(\text{Readout start position}) < (\text{Readout end position})$
 $\{(\text{Readout end position}) - (\text{Readout start position})\} < 16$

- Internal Color Bar Output Setting (For XCL-U1000C only)

[Command] COLORBAR
 [Parameter1] <Mode (0 to 1)>
 0: OFF
 1: ON
 [Process] Selects whether to output the internal color bar.

- Internal Gray Scale Output Setting (For XCL-U1000 only)

[Command] GRAYSCALE
 [Parameter1] <Mode (0 to 1)>
 0: OFF
 1: ON
 [Process] Selects whether to output the internal gray scale.

- Serial Communication Speed Setting

[Command] BRATE
 [Parameter1] <Baud rate setting (0 to 4)>
 0: 4800 [bps]
 1: 9600 [bps]
 2: 19200 [bps]
 3: 38400 [bps]
 4: 57600 [bps]
 [Process] Selects a serial communication speed.

IN/OUT Setting Commands

- External Trigger Signal Input Selection

[Command] EXTTRG
 [Parameter1] <Specified input (0 to 1)>
 0: Camera Link
 → Inputs signals via a Camera Link connector.
 1: DC
 → Inputs signals via a DC connector.
 [Process] Selects an input path for external trigger signals.

Setting Value Control Commands

Setting value control commands are used to control camera setting data saved in a Flash ROM. See the table below for details.

Command	Description
Initialize Setting	Returns all data related to camera control commands to the factory default values.
Save Setting	Writes all data related to camera control commands into Flash ROM.
Read Setting	Reads all data related to camera control commands from Flash ROM.
Get Setting Value	Sends data to a camera control application.

Initialize Setting Command

- Setting Initialization
 - [Command] INIT
 - [Process] Returns all data related to camera control commands to the factory default values.

Save Setting Command

- Setting Save
 - [Command] SAVE
 - [Process] Writes all data related to camera control commands to the Flash ROM.

The camera does not accept another command during an execution of command. The following messages appear when the execution is completed.

“OK”: Completed normally.

“ERROR STATUS”: An error occurred.

Note

An occurrence of error may indicate that the data in a destination media is damaged. Try saving again with the power ON.

Read Setting Command

- Setting Read
 - [Command] LOAD
 - [Process] Reads all data related to camera control commands from Flash ROM.

Get Setting Value Command

- Setting Value Acquisition
 - [Command] RMEM
 - [Process] Sends information on the camera (its version and whether it is a color video camera/monochrome video camera) and all the data that can be set using a serial communication to the camera control application software. The camera does not accept another command during data transmission.
 - [Data Transmission] Continuously transmits data by category. <CR> indicates the end of transmission. The data (except for version information) is sent in a decimal number format.

The format and an example of transmission are shown below.

<Format>

<Category>,<Data1>,<Data2>,...,<Category>,<Data1>,<Data2>,...,.....,<CR>

<Example of transmission>

CA,1.00,1,AF,250,120,SH,0,0,0,0,WB,...,.....,TF,...,<CR>

The table below details the camera control commands by category. (The data shown in block letters are not used with a camera control application.)

Name of category	Description	Number of data	Data
CA	Information on the camera	2	<Version> <Color/Black and White>
AF	AFE	2	<AFE gain> <Clamp level>
SH	Shutter/Trigger	5	<Shutter speed>, <Trigger mode>, <External trigger pulse polarity>, <External trigger delay>, <Internal trigger pulse cycle>
WB	WB	7	<White balance mode>, <Manual R gain>, <Manual B gain>, <AWB detection range display>, <AWB R gain> , <AWB Gb gain> , <AWB B gain>
OB	OB	8	<Offset>, <Black balance mode> , <Manual R offset> , <Manual B offset> , <Manual Gb offset> , <ABB R offset> , <ABB B offset> , <ABB Gb offset>
DT	DTL	11	<K0 setting value>, <K1 setting value>, <K2 setting value>, <Negative threshold> , <Positive threshold> , <Negative enhancement level>, <Positive enhancement level>, <Lower limit of enhancement> , <Upper limit of enhancement> , <Sharpness setting> , <DTL mode setting>
CL	Color	10	<MTX mode>, <MTX0>, <MTX1>, <MTX2>, <MTX3>, <MTX4>, <MTX5>, <MTX6>, <MTX7>, <MTX8>
GM	Gamma	2	< γ table>, < γ binarization threshold>
HR	Binning/Partial	4	<Binning mode>, <Partial scan mode>, <Partial scan readout start position>, <Partial scan readout end position>
IO	IN/OUT	4	<External trigger signal input selection>, <Output data clock phase> , <Bayer data output mode>, <Internal color bar output mode>
AJ	Adjustment data	43	<Black level>, <Gain (0 db)>, ..., <Gain (18 db)>, <R offset>, <B offset>, <Gb offset>, <R gain (3200 K)>, <Gb gain (3200 K)>, <B gain (3200 K)>, <R gain (5600 K)>, <Gb gain (5600 K)>, <B gain (5600 K)>, <R gain (6500 K)>, <Gb gain (6500 K)>, <B gain (6500 K)>, <MTX0>, ..., <MTX adjust value8>, <MTX detection range display>
TG	TG setting	7	<TG category0>, <TG category1>, ..., <TG category6>
AD	AFE setting	4	<Operation>, <Control>, <Clamp Level>, <VGA Gain>
PR	DSP PRO setting	14	<PRO setting0>, <PRO setting1>, ..., <PRO setting13>
BY	DSP B2Y setting	50	<B2Y setting0>, <B2Y setting1>, ..., <B2Y setting49>
TF	DSP TFR setting	13	<TFR setting0>, <TFR setting1>, ..., <TFR setting12>

[Camera information]

<Version (0.01 to)>

Indicates the software version.

<XCL-U1000C/XCL-U1000>

0: XCL-U1000

1: XCL-U1000C

Other Commands

■ Version Display

[Command] VERSION

[Process] Displays a model name and a software version.

```
<Input>          VERSION <CR>
<Output on screen> XCL-U1000C or XCL-U1000 <CR>
                   ver x.xx <CR>
```

■ Help Display

[Command] HELP

[Parameter 1] <Command>

[Process] The help for the specified command is shown. If no command name is specified, a list of available commands appears. (Available commands differs depending on modes or the type of camera (color or black & white.)

Command Restriction

There is a case in which a valid input of a parameter is ignored if it is set in conjunction with some other settings.

In such a case, the input becomes invalid and “ERROR STATUS” appears on the screen.

Shutter Speed Condition

It differs depending on whether the trigger mode is set to ON or OFF.

○ : Setting available.

X : Setting unavailable.

When the trigger mode is set to other than OFF

Trigger mode setting	Shutter speed setting		
	OFF	Mid-speed area	Low-speed area*
External trigger edge detection	X	○	X
External trigger pulse width detection	○	X	X
Internal trigger output	X	○	X

* Low-speed area is the area in which a shutter speed exceeds a VD cycle.

VDO interval		1/10000s	1/5000s	1/2000s	1/1000s	1/500s	1/250s	1/120s	1/100s	1/30s	1/15s	1/7.5s	1/2s	1s	2s
LXGA full	66.78	0.100ms	0.200ms	0.500ms	1.000ms	2.000ms	4.000ms	8.333ms	10.00ms	33.33ms	66.67ms	133.6ms	500.0ms	1.000s	2.000s
Partial	15/16	62.46													
	14/16	58.83													
	13/16	55.26													
	12/16	51.63													
	11/16	48.06													
	10/16	44.43													
	9/16	40.86													
	8/16	37.23													
	7/16	33.66													
	6/16	30.03													
	5/16	26.46													
	4/16	22.83													
	3/16	19.25													
	2/16	15.63													
	1/16	12.05													
Binning	33.39														

Command List

The following table lists the camera control commands:

Command	Parameter1	Parameter2	Parameter3	Description
GAIN-STEP	Gain	—	—	Gain-Step Setting
GAIN-FINE	Gain	—	—	Gain-Fine Adjustment
PEDESTAL	Clamp Level	—	—	Clamp Level Setting
SHUTTER	Shutter Setting	—	—	Shutter Speed Setting
TRG-MODE	Mode	—	—	Trigger Mode Setting
TRG-POL	Mode	—	—	External Trigger Polarity Setting
TRG-DELAY	Delay Time	—	—	External Trigger Delay Setting
TRG-CYCLE	Trigger Cycle Setting	—	—	Internal Trigger Cycle Setting
TRG-OUT	—	—	—	Internal Trigger Output
WBMODE	Mode	—	—	White Balance Setting
RGAIN	Gain	—	—	Manual R Gain Setting
BGAIN	Gain	—	—	Manual B Gain Setting
AWBWINDOW	Mode	—	—	AWB Detection Range Display
AUTOWB	—	—	—	One Push AWB Execution
DTL-COEF	K0 Setting Value	K1 Setting Value	K2 Setting Value	HPF Filter Coefficient Setting
DTL-TH	Negative Threshold	Positive Threshold	—	HPF Coring Threshold Setting
DTL-SCL	Negative Enhancement Level	Positive Enhancement Level	—	HPF Data Scale Setting
DTL-LVL	Lower Limit of Enhancement	Upper Limit of Enhancement	—	HPF Data Level Setting
SHARP	Sharpness	—	—	Sharpness Setting
DTL-MODE	Mode	—	—	DTL Mode Setting
COLORMTX	Mode	MTX Element	MTX Setting Value	Color Matrix Setting
GAMMA	Mode	—	—	γ Table Setting
BINARIZE	Binalization Setting Value	—	—	γ Binalization Threshold Setting
BINNING	Mode	—	—	Binning Mode Setting
PARTIAL	Mode	Readout Start Position	Readout End Position	Partial Scan Setting
EXTTRG	Input Setting	—	—	External Trigger Signal Input Selection
COLORBAR	Mode	—	—	Color Bar Output Setting
GRAYSCALE	Mode	—	—	Gray Scale Output Setting
BRATE	Baud rate Setting	—	—	Serial Communication Speed Setting
ADJUST	Adjustable Items	—	—	Automatic Adjustment Execution
MTXWINDOW	Mode	—	—	MTX Adjustment Detection Range Display
TGSET	Category	Registor Setting Value	—	TG/SG IC Setting Value
AFESET	Registor Name	Registor Setting Value	—	AFE IC Setting
DSPPSET	Setting Registor	Registor Setting Value	—	DSP Preprocess Setting
DSPCSET	Setting Registor	Registor Setting Value	—	DSP Color Processing Setting
DSPTSET	Setting Registor	Registor Setting Value	—	DSP Data Transfer Setting
INIT	—	—	—	Initialization
SAVE	—	—	—	Save Setting
LOAD	—	—	—	Read Setting
RMEM	—	—	—	Setting Value Acquisition
VERSION	—	—	—	Version Display
HELP	Command Name	—	—	Help Display

Specifications

Specifications

Imaging system

Pickup device	Progressive scan 1/1.8 type CCD
Effective picture elements (horizontal/vertical)	1,628 × 1,236
CCD vertical drive frequency	18.75 kHz
CCD horizontal drive frequency	36.0 MHz
Cell size (horizontal/vertical)	4.4 × 4.4 μm
Chip size (horizontal/vertical)	8.5 × 6.8 mm

Optical system and others

Lens mount	C-mount
Flange focal length	17.526 mm
Synchronization	Internal
Video output	Digital output XCL-U1000C: R/G/B 8 bits LVDS Reference video output level: 235 steps Reference pedestal level: 16 steps XCL-U1000: 10 bits LVDS Reference video output level: 940 steps Reference pedestal level: 64 steps Monitor output (analog output) Reference video output level: 700 mV HD frequency: 75 kHz positive VD frequency: 60 Hz positive

Output signal frequency	15 Hz
Effective lines	1,600 × 1,200
Sensitivity	XCL-U1000C: 2,000 lx, F8 XCL-U1000: 400 lx, F5.6
Minimum illumination	XCL-U1000C: 4 lx (gain: +18 dB, F1.4) XCL-U1000: 2 lx (gain: +18 dB, F1.4)
Gain	0 to +18 dB
γ	OFF/ON
Read mode	XCL-U1000C: normal/high rate scan XCL-U1000: normal/binning/ high rate scan
Detail	OFF/ON
White balance (XCL-U1000C only):	preset/manual/AWB
Matrix (XCL-U1000C only):	OFF/ON
Shutter	External trigger shutter
Shutter speed	External trigger shutter: 1 to 1/10000 sec.
Power	+12 V DC (Range: +10.5 to 15 V)
Power consumption	5.5 W
Operating temperature:	-5 to +45°C (23 to 113°F)
Storage temperature:	-30 to +60°C (-22 to 140°F)
Operating relative humidity:	20 to 80% (no condensation)
Storage relative humidity:	20 to 95% (no condensation)
Vibration resistance	10 G (20 Hz to 200 Hz)
Shock resistance	70 G
MTBF	49,059 h (Approx. 5.6 years)
External dimension (w/h/d)	56 × 44 × 95 mm (2 1/4 × 1 3/4 × 3 3/4 inches)

Mass	250 g (9 oz)
Accessories	Lens mount cap (1) Operating Instructions (1)

Design and specifications are subject to change without notice.

IMPORTANT

The nameplate is located on the bottom.

Spectral Sensitivity Characteristics (Typical Values)

XCL-U1000C

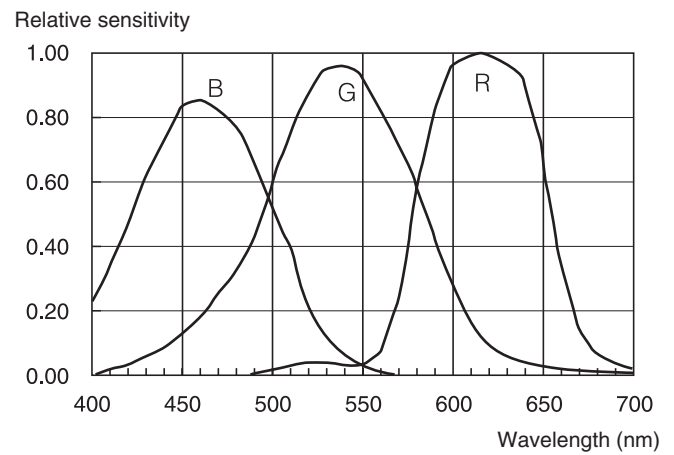

XCL-U1000

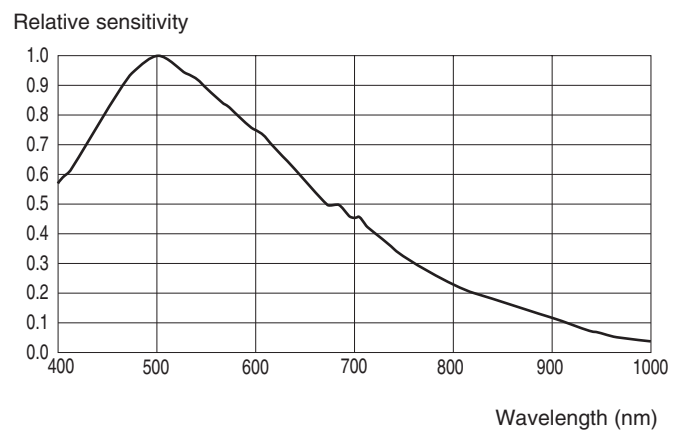

(Lens characteristics included, and light source characteristics excluded.)

XCL-U1000C/U1000 Dimensions

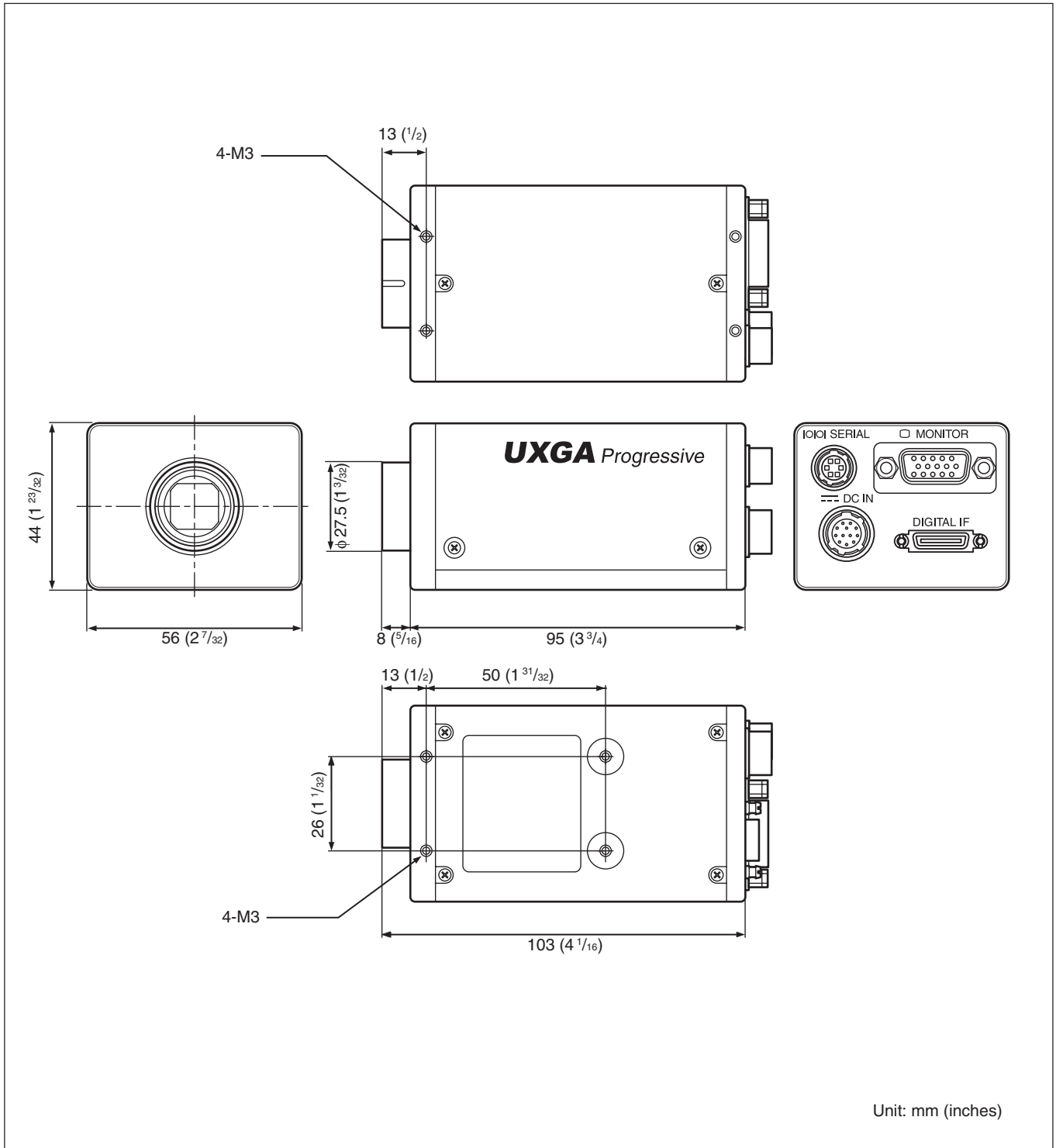

Sony reserves the right to change specifications of the products and discontinue products without notice. Technical information contained herein is for reference only and does not convey any license by any implication or otherwise under any intellectual property right or other right of Sony or third parties. Sony cannot assume responsibility for any right infringements arising out of the use of this information.