

HD Color Camera Module

Technical Manual



FCB-H11

Table of Contents

Features	3
Precautions	4
Locations of Controls	5
Basic Functions	6
Overview of Functions	6
Eclipse	12
Vibration Specifications	12
Initial Settings and Position Preset	13
Mode Condition	14
Command List	18
VISCA/RS-232C Commands	18
FCB-H11 Commands	24
Specifications	36

Features

- The CMOS video camera provides 2,000,000 effective picture elements (pixels) that can shoot high-definition images to offer superior picture quality.
- The camera is compatible with 8 formats, including the Full HD (1080i high definition) video format, which is equivalent to an HD-TV broadcast.
HD: 1080i/59.94, 1080i/50, 720p/59.94, 729p/50
SD: NTSC (CROP), NTSC (SQUEEZE)
PAL (CROP), PAL (SQUEEZE)
- Video outputs
HD: Analog Component
SD: VBS, Y/C
- The camera is equipped with an $\times 10$ optical auto focus zoom lens.
- The $\times 12$ digital zoom function allows you to zoom up to $\times 120$, combined with a optical zoom.
- An infrared (IR) Cut-Filter can be disengaged from the image path for increased sensitivity in low light environments. The ICR will automatically engage depending on the ambient light, allowing the camera to be effective in day/night environment.
- The VISCA is a communication protocol, which enables the camera to be controlled from a computer. You can select the baud rate from among 9600 bps, 19200 bps, or 38400 bps. This allows you to remotely control the camera at a high communication speed.
- The position preset function allows the camera to store up to six combinations of settings of camera shooting conditions. Also, the custom preset function allows you to customize the initial settings of each function when the power of the camera is turned on.

With consideration given to environmental protection, this module is designed to operate with low power consumption and also incorporates lead-free and halogen-free circuit boards.

Precautions

Software

Use of demonstration software developed by Sony Corporation or use of customer developed application software may damage hardware, the application program, or the camera. Sony Corporation is not liable for any damage that may occur under these conditions.

Operation

Start the camera control software on your computer after you turn on the camera and the image is displayed.

Operation and storage locations

Do not shoot images that are extremely bright (e.g., light sources, the sun, etc.) for long periods of time. Do not use or store the camera in the following extreme conditions:

- Extremely hot or cold places (operating temperature 0 °C to +45 °C (32 °F to 113 °F))
- Close to generators of powerful electromagnetic radiation such as radio or TV transmitters
- Where it is subject to fluorescent light reflections
- Where it is subject to unstable (flickering, etc.) lighting conditions
- Where it is subject to strong vibration
- Where it is subject to radiation from laser beams
- Where it is subject to internal atmospheric temperatures that exceed the camera's operating temperature range (0 °C to +45 °C (32 °F to 113 °F))

Care of the unit

Remove dust or dirt on the surface of the lens with a blower (commercially available).

Other

Do not apply excessive voltage. (Use only the specified voltage.) Otherwise, you may get an electric shock or a fire may occur.

In case of abnormal operation, contact your authorized Sony dealer or the store where you purchased the product.

Phenomena specific to CMOS image sensors

The following phenomena that may appear in images are specific to CMOS (Complementary Metal Oxide Semiconductor) image sensors. They do not indicate malfunctions.

White flecks

Although the CMOS image sensors are produced with high-precision technologies, fine white flecks may be generated on the screen in rare cases, caused by cosmic rays, etc.

This is related to the principle of CMOS image sensors and is not a malfunction.

The white flecks especially tend to be seen in the following cases:

- when operating at a high environmental temperature
- when you have raised the master gain (sensitivity)
- when operating in Slow-Shutter mode

The above phenomena may be mitigated somewhat by turning the power off once, and then turning it on again.

Aliasing

When fine patterns, stripes, or lines are shot, they may appear jagged or flicker.

Locations of Controls

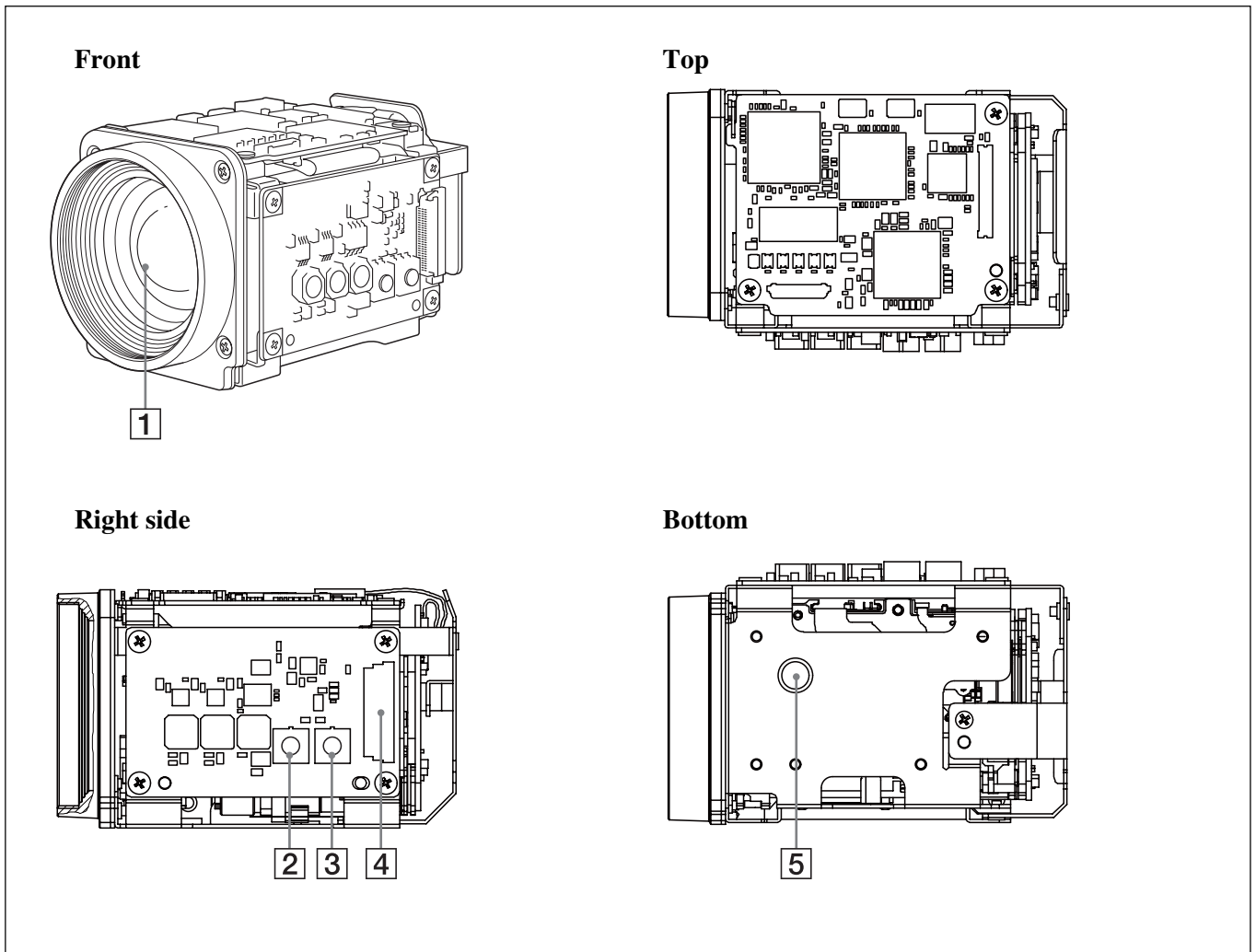

- 1 Lens
- 2 WIDE button
- 3 TELE button

- 4 CN901 jack
- 5 Tripod screw hole

When a tripod is used, please use 5 mm ($7/32$ inches) or less screw to attach it to the camera. Also, please be sure to attach the tripod securely.

Basic Functions

Overview of Functions

VISCA commands are the basis of camera control.

In general

- **Power On/Off**
Powers the camera on and off. When the power is off, the camera is able to accept only the lowest level of VISCA Commands; the display and other features are turned off.
- **I/F clear**
Clears the Command buffer of the FCB-H11 camera. Clearing the buffer can also be carried out from the control application software when the power is on.
- **Address set**
VISCA is a protocol, which normally can support a daisy chain of up to seven attached devices. In this case, if addresses from 1 to 7 are assigned to each of 7 devices, you can control seven cameras with the same personal computer. However, the FCB-H11 camera does not support connection of cameras in a daisy chain. Therefore, whenever a camera is connected for the first time, be sure to use the address set to confirm the address.
- **ID Write**
Sets the camera ID.
- **Mute**
Blanks the screen and sends out a synchronizing signal.

Zoom

The camera employs an 10× optical zoom lens combined with a digital zoom function allowing you to zoom up to 120×.

Lens specifications: Optical 10×, f = 5.1 to 51 mm (F1.8 to F2.1)

The horizontal angle of view is approximately 50 degrees (wide end) to 5.4 degrees (tele end). Digital Zoom enlarges the center of the subject by expanding each image in both the vertical and horizontal directions. When 12× digital zoom is used, the number of effective picture elements in each direction reduces to $1/12$ and the overall resolution deteriorates.

You can activate the zoom in the following two ways:

- **By pressing the TELE or WIDE buttons on the camera.**
- **Using a VISCA Command**

Using Standard Mode

Using Variable Mode

There are eight levels of zoom speed.

Direct Mode

Setting the zoom position enables quick movement to the designated position.

Focus

Focus has the following modes, all of which can be set using VISCA Commands.

- **Auto Focus Mode**

The Auto Focus (AF) function automatically adjusts the focus position to the high frequency content of the picture in a center measurement area, taking into consideration the high luminance and strong contrast components.

The minimum focus distance is 10 mm at the optical wide end (extreme close-up settings with VISCA control) (distance from the front end of the lens).

- **Normal AF Mode**

This is the normal mode for AF operations.

- **Interval AF Mode**

The mode used for AF movements carried out at particular intervals. The time intervals for AF movements and for the timing of the stops can be set in one-second increments using the Set Time Command. The initial value for both is set to five seconds.

- **Zoom Trigger Mode**

When the zoom is changed with the TELE or the WIDE buttons, the pre-set value (initially set at 5 seconds) becomes that for AF Mode. Then, it stops.

- **Manual Focus Mode**

MF (Manual Focus) has both a Standard Speed Mode and a Variable Speed Mode. Standard Speed Mode focuses at a fixed rate of speed. Variable Speed Mode has eight speed levels that can be set using a VISCA Command.

To stop the required operation after sending a Standard Speed command or a Variable Speed command, send the Stop command.

- **One Push Trigger Mode**

When a Trigger Command is received, the lens moves to adjust the focus for the subject. The focus lens then holds the same position until the next Trigger Command is input.

- **Infinity Mode**

The lens is forcibly moved to a position suitable for an unlimited distance.

- **Near Limit Mode**

Can be set in a range from about 4.5 m (2000) to 1 cm (C000).

The focus range is narrowed by excluding the unnecessary range.

White Balance

White Balance has the following modes, all of which can be set using VISCA Commands.

- **Auto White Balance**

This mode computes the white balance value output using color information from the entire screen. It outputs the proper value using the color temperature radiating from a black subject based on a range of values from 3000 to 7500K.

This mode is the default setting.

- **Indoor**

3200 K Base Mode

- **Outdoor**

5800 K Base Mode

- **One Push WB**

The One Push White Balance mode is a fixed white balance mode that may be automatically readjusted only at the request of the user (One Push Trigger), assuming that a white subject, in correct lighting conditions and occupying more than $\frac{1}{2}$ of the image, is submitted to the camera.

One Push White Balance data is lost when the power is turned off. If the power is turned off, reset the One Push White Balance.

- **Manual WB**

Manual control of R and B gain, 256 steps each

Automatic Exposure Mode

The variety of AE functions, which allow video signal to output the optimum image for subjects from low light conditions to bright light conditions, are available.

- **Full Auto**

Auto Iris and Gain, Fixed Shutter Speed (59.94/NTSC: $\frac{1}{60}$ s, 50/PAL: $\frac{1}{50}$ s)

- **Slow shutter limit**

Lower limit of the slow shutter mode in the Full Auto mode. For the 59.94/NTSC video format, select the lower limit from among $\frac{1}{60}$, $\frac{1}{30}$, $\frac{1}{15}$, $\frac{1}{8}$, $\frac{4}{1}$ or $\frac{1}{2}$.

For the 50/PAL video format, select the lower limit from among $\frac{1}{50}$, $\frac{1}{25}$, $\frac{1}{12}$, $\frac{1}{6}$, $\frac{1}{3}$ or $\frac{1}{2}$.

- **Shutter Priority**¹⁾

Variable Shutter Speed, Auto Iris and Gain ($\frac{1}{2}$ to $\frac{1}{10,000}$ s, 21 steps, high speed shutter: 15 steps, slow shutter: 6 steps)

- **Iris Priority**

Variable Iris (F1.8 to Close, 18 steps), Auto Gain and Shutter speed.

- **Manual**

Variable Shutter, Iris and Gain.

- **Bright**

Variable Iris and Gain (Close to F1.8, 18 steps at 0 dB: F1.8, 6 steps from 0 to 18 dB)

- **Spot light**

Avoids a situation where the face of the subject is over-illuminated, and becomes whitish.

AE – Shutter Priority

The shutter speed can be set freely by the user to a total of 21 steps – 15 high speeds and 6 low speeds. When the slow shutter is set, the speed can be $\frac{1}{30}$, $\frac{1}{15}$, $\frac{1}{8}$, $\frac{1}{4}$, or $\frac{1}{2}$ s. The picture output is read at a normal rate from the memory. The memory is updated at a low rate from the CCD. AF capability is low. In high speed mode, the shutter speed can be set up to $\frac{1}{10,000}$ s. The iris and gain are set automatically, according to the brightness of the subject.

Parameter	59.94i	50i
	[sec]	[sec]
15	1/10000	1/10000
14	1/6000	1/6000
13	1/4000	1/3500
12	1/3000	1/2500
11	1/2000	1/1750
10	1/1500	1/1250
0F	1/1000	1/1000
0E	1/725	1/600
0D	1/500	1/425
0C	1/350	1/300
0B	1/250	1/215
0A	1/180	1/150
09	1/125	1/120
08	1/100	1/100
07	1/90	1/75
06	1/60	1/50
05	1/30	1/25
04	1/15	1/12
03	1/8	1/6
02	1/4	1/3
01	1/2	1/2

Note

When the low shutter speed is used, Auto Focus and White Balance may not function fully.

1) Flicker can be eliminated by setting shutter to:
→ $\frac{1}{100}$ s for NTSC models used in countries with a 50 Hz power supply frequency.

→ $\frac{1}{120}$ s for PAL models used in countries with a 60 Hz power supply frequency.

AE – Iris Priority

The iris can be set freely by the user to 18 steps between F1.8 and Close.

The gain and shutter speed are set automatically according to the brightness of the subject.

parameter	IRIS (F1.8) F No.	parameter	IRIS (F1.8) F No
11	F1.8	08	F8.0
10	F2.0	07	F9.6
0F	F2.4	06	F11
0E	F2.8	05	F14
0D	F3.4	04	F16
0C	F4.0	03	F19
0B	F4.8	02	F22
0A	F5.6	01	F26
09	F6.8	00	CLOSE

AE – Manual

The shutter speed (21 steps), iris (18 steps) and gain (8 steps) can be set freely by the user.

AE – Bright

The bright control function adjusts both the gain and iris using an internal algorithm according to a brightness level freely set by the user. Exposure is controlled by gain when dark and by iris when bright. As both gain and iris are fixed, this mode is used when exposing at a fixed camera sensitivity. When switching from Full Auto or Shutter Priority Mode to Bright Mode, the current status will be retained for a short period of time.

Only when the AE mode is set to “Full Auto” or “Shutter Priority,” the user can switch it to “Bright.”

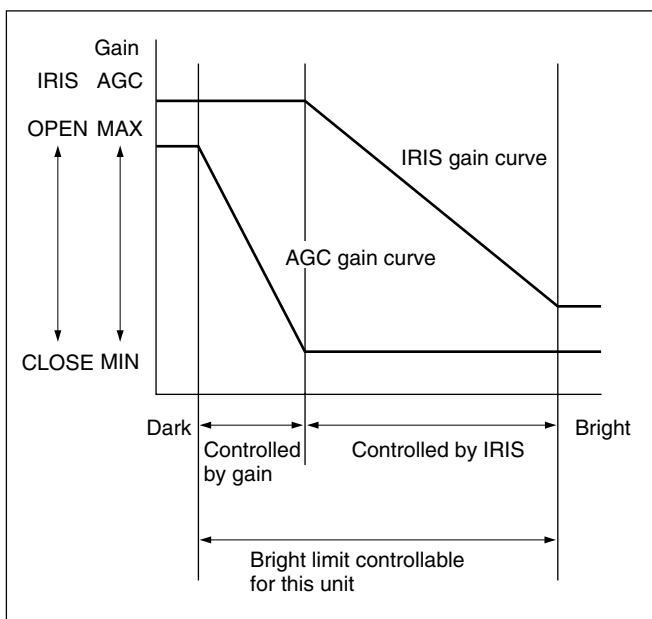

Parameter	IRIS (F1.8) F No.	GAIN
17	F1.8	18dB
16	F1.8	15dB
15	F1.8	12dB
14	F1.8	9dB
13	F1.8	6dB
12	F1.8	3dB
11	F1.8	0dB
10	F2.0	0dB
0F	F2.4	0dB
0E	F2.8	0dB
0D	F3.4	0dB
0C	F4.0	0dB
0B	F4.8	0dB
0A	F5.6	0dB
09	F6.8	0dB
08	F8.0	0dB
07	F9.6	0dB
06	F11	0dB
05	F14	0dB
04	F16	0dB
03	F19	0dB
02	F22	0dB
01	F26	0dB
00	CLOSE	0dB

When switching from the Shutter Priority mode to the Bright mode, the shutter speed set in the Shutter Priority mode is maintained.

Spot Exposure Mode

In Full Auto AE, the level for the entire screen is computed and the optimum Auto Iris and Gain levels are determined. In Spot AE, a particular section of the subject can be designated, and then that portion of the image can be weighted and a value computed so that Iris and Gain can be optimized to obtain an image. For example, in an image with a lot of movement and with varying levels of brightness, portions without much change can be designated as such a “spot,” and changes to the screen can be minimized in that area. As shown in the following diagram on the next page, a range of 16 blocks vertically and 16 blocks horizontally can be designated. In the case where the center is designated (shown in black), the level is computed along with a weighted value for the surrounding block (shaded), including the specified portions; and then the Gain and Iris are set. The value of the designated portions and the surrounding areas should be calculated as 100%, the

rest should be set to 20%. The range of the Spot AE frame is fixed to 5 blocks vertically and 4 blocks horizontally.

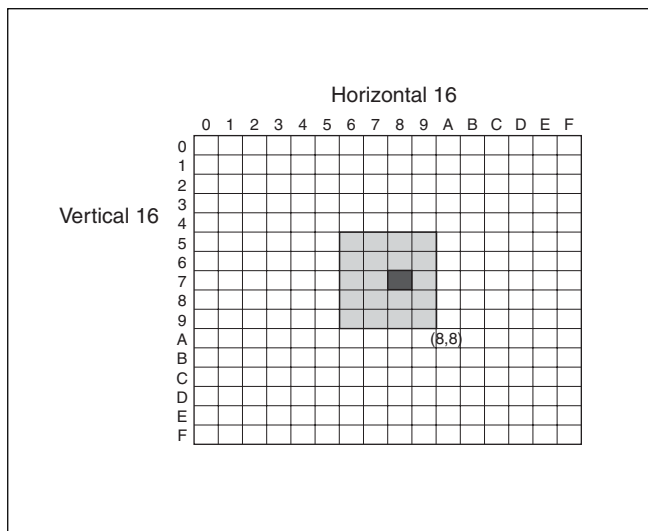

Exposure Compensation

Exposure compensation is a function which offsets the internal reference brightness level used in the AE mode by steps of 1.5 dB.

EXPOSURE	Comp Value	Step
0E	+10.5dB	+7
0D	+9dB	+6
0C	+7.5dB	+5
0B	+6dB	+4
0A	+4.5dB	+3
09	+3dB	+2
08	+1.5dB	+1
07	0dB	0
06	-1.5dB	-1
05	-3dB	-2
04	-4.5dB	-3
03	-6dB	-4
02	-7.5dB	-5
01	-9dB	-6
00	-10.5dB	-7

Aperture Control

Aperture control is a function which adjusts the enhancement of the edges of objects in the picture. There are 16 levels of adjustment, starting from “no enhancement.” When shooting text, this control may help by making the text sharper.

Back Light Compensation

When the background of the subject is too bright, or when the subject is too dark due to shooting in the AE mode, back light compensation will make the subject appear clearer.

ICR (IR Cut-Removable) Mode

An infrared (IR) Cut-Filter can be disengaged from the image path for increased sensitivity in low light environments. The ICR will automatically engage depending on the ambient light, allowing the camera to be effective in day/night environments.

When the auto ICR mode is set to ON, the image becomes black and white.

Auto ICR Mode

Auto ICR Mode automatically switches the settings needed for attaching or removing the IR Cut Filter. With a set level of darkness, the IR Cut Filter is automatically disabled (ICR ON), and the infrared sensitivity is increased. With a set level of brightness, the IR Cut Filter is automatically enabled (ICR OFF). Also, on systems equipped with an IR light, the internal data of the camera is used to make the proper decisions to avoid malfunctions.

Slow shutter – Auto/Manual

When set to “Auto,” ensures that the slow shutter is set automatically within the range of the lower limit set by the slow shutter limit command, when the brightness drops. Effective only when the AE mode is set to “Full Auto.”

Set to “Slow Shutter Auto” at shipment from the factory.

Camera ID

The ID can be set up to 65,536 (0000 to FFFF). As this will be memorized in the nonvolatile memory inside the camera, data will be saved, regardless of the “position preset.”

Effect

It consists of the following functions.

- **Neg. Art:** Negative/Positive Reversal
- **Black White:** Monochrome Image

Gamma

Selects the desired gamma curve of the camera.

- **Normal**

Reproduces images with the standard video gamma curve.

- **Cinema Type 1**

Reproduces images that look lively, providing depth in images as if you shot them using a film.

- **Cinema Type 2**

In addition to the features of Cinema Type 1, this setting is capable of extremely precise description of the entire exposure zone, from shadowed parts to highlighted parts, which enables reproduction of a deeper black.

The settings are recalled when the power is turned on.

For setting items, see the “Initial Settings and Position Preset” section on page 13.

Custom Preset

As with the position preset function, the camera shooting conditions can be stored and recalled. The settings are recalled when the power is turned on.

For setting items, see the “Initial Settings and Position Preset” section on page 13.

Freeze

This function captures an image in the field memory of the camera so that this image can be output continuously.

Because communication inside the camera is based on V cycle, the captured image is always the one 3V to 4Vs after the sending of a Command. Thus, you can not specify a time period after sending EVEN, ODD or a Command.

Others

Memory (Position Preset)

Using the position preset function, 6 sets of camera shooting conditions can be stored and recalled. This function allows you to achieve the desired status instantly even without adjusting the following items each time:

- **Zoom Position**
- **Focus Auto/Manual**
- **Focus Position**
- **AE Mode**
- **Shutter control parameters**
- **Bright Control**
- **Iris control parameters**
- **Gain control parameters**
- **Exposure Compensation On/Off**
- **Exposure Level**
- **Backlight Compensation On/Off**
- **Slow shutter Auto/Manual**
- **White Balance Mode**
- **R/B Gain**
- **Aperture**
- **ICR Shoot On/Off**

Eclipse

When designing the housing, refer to the dimensional allowance as shown in the figure below.

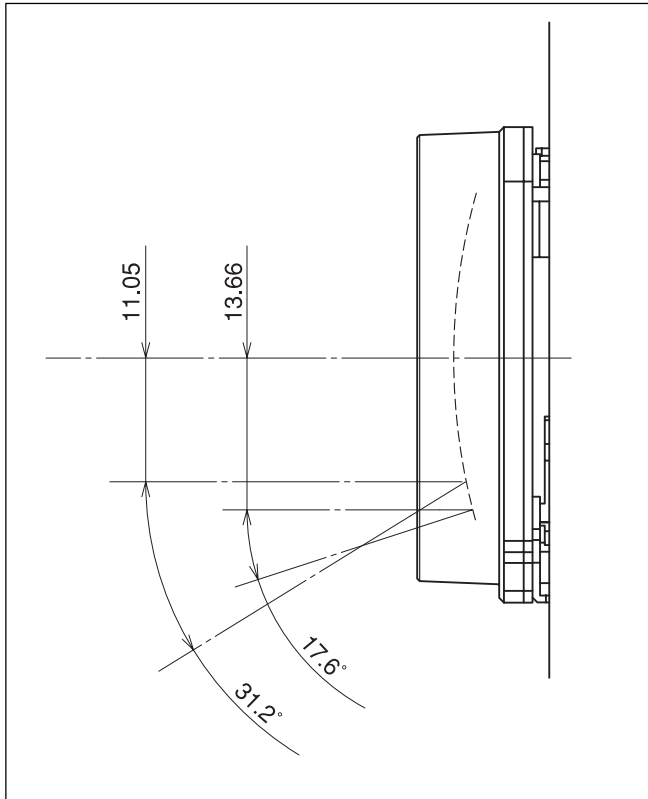

Vibration Specifications

Test Method (Random vibration)

- Fix the camera at the four fixation points of the base using M2 screws.
- Perform the random vibration test under the following conditions in the X, Y and Z directions for 20 minutes in each direction.
- The camera vibration specification is to have no malfunction after this test.

Power spectrum density	5 to 50 Hz	4.14 m ² /s ³	{0.043 G ² /Hz}
	50 to 100 Hz	-36 dB/oct	
Effective overall value	14.3 m/s ²		{1.46 G}
Test time	20 minutes		

Initial Settings and Position Preset

The initial values are those set at the factory. Settings for items that will be retained even when the power to the camera is turned off are indicated by a “○,” those that will be lost are indicated by an “×.”

Mode/Position	Initial settings	Custom preset	Memory position presets 0 to 5
Zoom Position	Wide end	○	○
Focus Position	—	○	○
Focus Auto/Manual	Auto	○	○
Near Limit Setting	C000h (1.0 cm)	○	×
AF Mode	Normal	○	×
AF activation time	5 seconds	○	×
AF interval time	5 seconds	○	×
WB Mode	Auto	○	○
WB Data (Rgain, Bgain)	—	○	○
One Push WB Data	—	○	×
AE Mode	Full Auto	○	○
Slow Shutter Mode	On	○	○
Shutter Position	1/60sec (59.94/NTSC), 1/50sec (50/PAL)	○	○
Iris Position	—	○	○
Gain Position	—	○	○
Bright Position	—	○	○
Exposure Compensation On/Off	Off	○	○
Exposure Compensation Amount	±0	○	○
Backlight On/Off	Off	○	○
Spot AE On/Off	Off	○	×
Spot AE position setting	X=8, Y=8	○	×
Gamma	Normal	○	×
Key Lock	Off	○	×
Aperture Level	8	○	○
Freeze On/Off	Off	×	×
Picture Effect	Off	○	×
Mute On/Off	Off	×	×
D-Zoom Limit	x4	○	○
AutoSlowShutterLimit	Off	○	○
ICR On/Off	Off	○	○
Auto ICR On/Off	Off	○	○
Auto ICR Threshold Level	0Ch	○	○

Notes

- The number of times data can be written to the EEPROM (by executing Position Preset) is limited.
- Camera ID data will be saved regardless of the position preset.

Mode Condition

Basic settings

Command	Mode	Power Off ¹⁾	Power On				
			IFC ²⁾	Initializing ³⁾	During displaying a still image	Other Status	Memory Command
Address Set		○	○	○	○	○	○
IF_Clear		○	○	○	○	○	○
CAM_Power On		○	×	○	○	○	×
CAM_Power Off		○	×	○	○	○	×
CAM Version Inq.		○	○	○	○	○	○
CAM_Power Inq.		○	○	○	○	○	○
BlockInquiry		×	×	○	○	○	×
InquiryCommand (and similar commands)		×	×	○	○	○	×

1) DC power is being supplied, but the camera has been turned off by a VISCA command.

2) The period from the time IF Clear is sent, until the Reply Packet is returned.

3) The period from the time DC power is turned on or the camera is turned on via a VISCA command, and the lens is initialized, until the video signal is output. Or the period from the time the CAM Power ON command is sent, until Completion is returned.

Zoom/Focus

Command	Mode	Power Off ¹⁾	Power On						
			IFC ²⁾	Initializing ³⁾	Zoom Direct	Focus Direct	AF ON	During displaying a still image	Memory Recall
CAM_Zoom Tele/Wide/Stop		×	×	×	×	○	○	×	×
CAM_Zoom Direct		×	×	○	○	○	○	×	×
D-Zoom Limit		×	×	×	○	○	○	×	×
CAM_Focus Far/Near/Stop		×	×	○	×	×	×	×	×
CAM_Focus Direct		×	×	○	○	○	○	×	×
CAM_Focus Mode (Auto/Manual)		×	×	○	×	×	×	○	×
CAM_Focus One Push Trigger		×	×	○	×	×	×	×	×
CAM_Focus Infinity		×	×	○	×	×	×	○	×
CAM_Focus Near Limit		×	×	○	×	×	×	○	×

1) DC power is being supplied, but the camera has been turned off by a VISCA command.

2) The period from the time IF Clear is sent, until the Reply Packet is returned.

3) The period from the time DC power is turned on or the camera is turned on via a VISCA command, and the lens is initialized, until the video signal is output. Or the period from the time the CAM Power ON command is sent, until Completion is returned.

White Balance

Command	Mode	Power Off ¹⁾	IFC ²⁾	Initializing ³⁾	Power On						
					White balance mode			During displaying a still image		Memory Recall	
					Auto	Indoor	Outdoor	One Push	Manual		
CAM_WB Auto/Indoor/Outdoor/OnePushWB/Manual		×	×	×	○	○	○	○	○	×	×
CAM_WB One Push Trigger		×	×	×	×	×	×	○ ⁴⁾	×	×	×
CAM_WB R(B) Gain Reset/Up/Down/Direct		×	×	×	×	×	×	×	○	×	×

1) DC power is being supplied, but the camera has been turned off by a VISCA command.

2) The period from the time IF Clear is sent, until the Reply Packet is returned.

3) The period from the time DC power is turned on or the camera is turned on via a VISCA command, and the lens is initialized, until the video signal is output. Or the period from the time the CAM Power ON command is sent, until Completion is returned.

4) Commands are ignored during a One Push A WB operation.

Exposure

Command	Mode	Power Off ¹⁾	IFC ²⁾	Initializing ³⁾	Power On							Memory Recall	
					Full Auto	Bright	Shutter Pri	Iris Pri	SPOT Light	Manual	During displaying a still image		
CAM_AE Full Auto/Manual/Shutter Pri/Iris Pri/Bright/Spot Light		×	×	×	○	○ ⁴⁾	○	○	○	○	○	×	×
CAM_AE Bright		×	×	×	○	○	○	×	×	×	×	×	×
CAM_Slow Shutter Limit ON/OFF		×	×	×	○	○	○	○	○	○	○	×	×
CAM_Shutter Reset/Up/Down/Direct ⁵⁾		×	×	×	×	×	○	×	×	×	○	×	×
CAM_Iris Reset/Up/Down/Direct		×	×	×	×	×	×	×	○	×	○	×	×
CAM_Gain Reset/Up/Down/Direct		×	×	×	×	×	×	×	×	×	○	×	×
CAM_Bright Reset/Up/Down/Direct		×	×	×	×	○	×	×	×	×	×	×	×
CAM_ExComp On/Off		×	×	×	○	○	○	○	○	○	○	×	×
CAM_ExComp Reset/Up/Down/Direct ⁶⁾		×	×	×	○	○	○	○	○	○	○	×	×
CAM_Backlight On/Off		×	×	×	○	×	×	×	×	○	×	×	×

1) DC power is being supplied, but the camera has been turned off by a VISCA command.

2) The period from the time IF Clear is sent, until the Reply Packet is returned.

3) The period from the time DC power is turned on or the camera is turned on via a VISCA command, and the lens is initialized, until the video signal is output. Or the period from the time the CAM Power ON command is sent, until Completion is returned.

4) ○: Only when the camera changes to BRIGHT mode from Full Auto or SHUTTER Pri mode.

5) You are not allowed to adjust the slow shutter setting while using Digital Effect.

6) ×: This is not allowed when EX-COMP is set to OFF.

Others

Command	Mode	Power Off ¹⁾	Power On				
			IFC ²⁾	Initializing ³⁾	Slow Shutter Status	Picture Effect ON	During displaying a still image
CAM_Aperture Reset/Up/Down/Direct		×	×	○	○	×	×
CAM_PictureEffect Off/Nega/B&W		×	×	○	○	×	×
ICR On/Off		×	×	×	○	○	×
Auto ICR On/Off		×	×	×	×	○	×
Auto ICR Threshold Level		×	×	×	×	○	×

1) DC power is being supplied, but the camera has been turned off by a VISCA command.

2) The period from the time IF Clear is sent, until the Reply Packet is returned.

3) The period from the time DC power is turned on or the camera is turned on via a VISCA command, and the lens is initialized, until the video signal is output. Or the period from the time the CAM Power ON command is sent, until Completion is returned.

Command List

VISCA¹⁾ /RS-232C Commands

Use of RS-232C control software which has been developed based upon this command list may cause malfunction or damage to hardware and software. Sony Corporation is not liable for any such damage.

Overview of VISCA

In VISCA, the side outputting commands, for example, a computer, is called the controller, while the side receiving the commands, such as an FCB-H11, is called the peripheral device. The FCB-H11 serves as a peripheral device in VISCA. In VISCA, up to seven peripheral devices like the FCB-H11 can be connected to one controller using communication conforming to the RS-232C standard. The parameters of RS-232C are as follows.

- Communication speed: 9600 bps/19200 bps/
38400 bps
- Data bits : 8
- Start bit : 1
- Stop bit : 1
- Non parity

Flow control using XON/XOFF and RTS/CTS, etc., is not supported.

1) VISCA is a protocol which controls consumer camcorders developed by Sony. "VISCA" is a trademark of Sony Corporation.

VISCA Communication Specifications

VISCA packet structure

The basic unit of VISCA communication is called a packet (Fig.1). The first byte of the packet is called the header and comprises the sender's and receiver's addresses. For example, the header of the packet sent to the FCB-H11 assigned address 1 from the controller (address 0) is hexadecimal 81H. The packet sent to the FCB-H11 assigned address 2 is 82H. In the command

list, as the header is 8X, input the address of the FCB-H11 at X. The header of the reply packet from the FCB-H11 assigned address 1 is 90H. The packet from the FCB-H11 assigned address 2 is A0H. Some of the commands for setting FCB-H11 units can be sent to all devices at one time (broadcast). In the case of broadcast, the header should be hexadecimal 88H. When the terminator is FFH, it signifies the end of the packet.

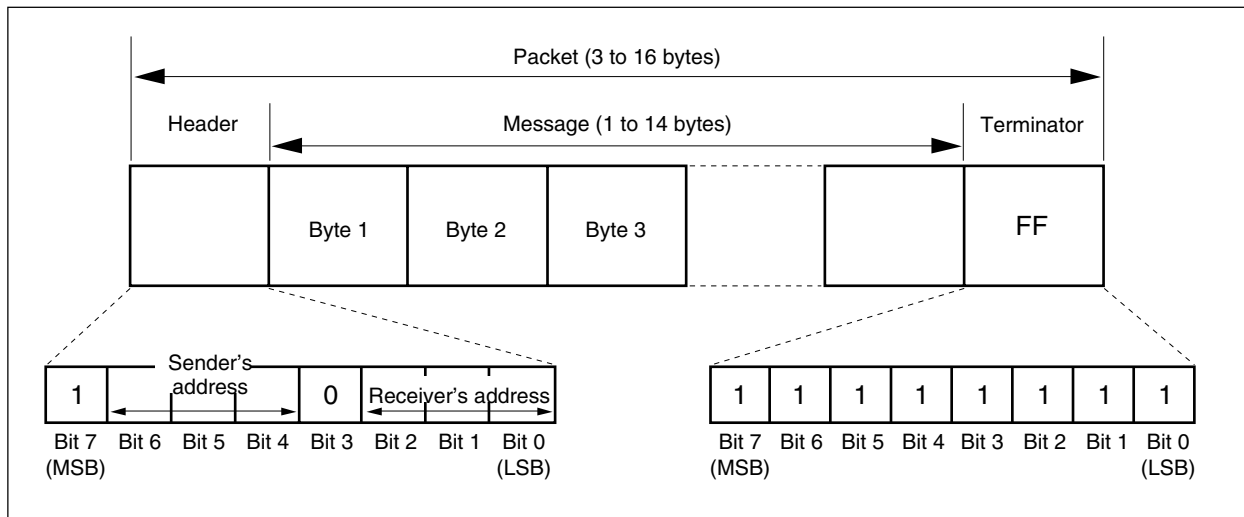

Fig. 1 Packet structure

Note

Fig. 1 shows the packet structure, while Fig. 2 shows the actual waveform. Data flow will take place with the LSB first.

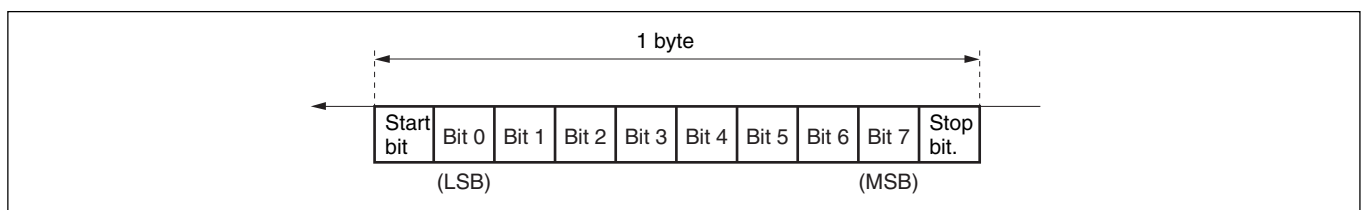
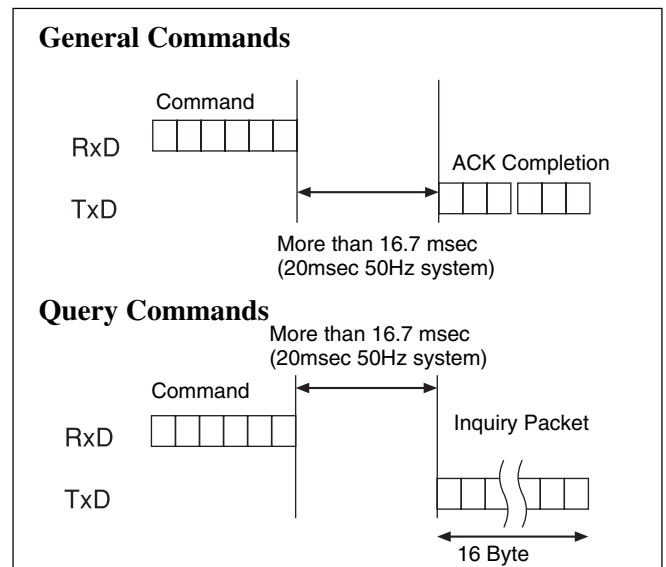

Fig. 2 Actual waveform for 1 byte.

Timing Chart

As VISCA Command processing can only be carried out one time in a Vertical cycle, it takes the maximum 1V cycle time for an ACK/Completion to be returned. If the Command/ACK/Completion communication time can be cut shorter than the 1V cycle time, then every 1V cycle can receive a Command.

From this point, if 2 or more commands in a row are to be sent, wait for the first command (for normal commands, an ACK or an error message, for query commands, an Inquiry Packet) to be carried out before sending the next one.



Command and inquiry

● Command

Sends operational commands to the FCB-H11.

● Inquiry

Used for inquiring about the current state of the FCB-H11.

	Command Packet	Note
Inquiry	8X QQ RR ... FF	QQ ¹⁾ = Command/Inquiry, RR ²⁾ = category code

¹⁾ QQ = 01 (Command), 09 (Inquiry)

²⁾ RR = 00 (Interface), 04 (camera 1), 06 (Pan/Tilter)

X = 1 to 7: FCB-H11 address

Responses for commands and inquiries

● ACK message

Returned by the FCB-H11 when it receives a command. No ACK message is returned for inquiries.

● Completion message

Returned by the FCB-H11 when execution of commands or inquiries is completed. In the case of inquiry commands, it will contain reply data for the inquiry after the 3rd byte of the packet. If the ACK message is omitted, the socket number will contain a 0.

	Reply Packet	Note
Ack	X0 4Y FF	Y = socket number
Completion (commands)	X0 5Y FF	Y = socket number
Completion (Inquiries)	X0 5Y ... FF	Y = socket number

X = 9 to F: FCB-H11 address + 8

● Error message

When a command or inquiry command could not be executed or failed, an error message is returned instead of the completion message.

Error Packet	Description
X0 6Y 02 FF	Syntax Error
X0 6Y 03 FF	Command buffer full
X0 6Y 04 FF	Command cancelled
X0 6Y 05 FF	No socket (to be cancelled)
X0 6Y 41 FF	Command not executable

X = 9 to F: FCB-H11 address + 8, Y = socket number

Socket number

When command messages are sent to the FCB-H11, it is normal to send the next command message after waiting for the completion message or error message to return. However to deal with advanced uses, the FCB-H11 has two buffers (memories) for commands, so that up to two commands including the commands currently being executed can be received. When the FCB-H11 receives commands, it notifies the sender which command buffer was used using the socket number of the ACK message.

As the completion message or error message also has a socket number, it indicates which command has ended. Even when two command buffers are being used at any one time, an FCB-H11 management command and some inquiry messages can be executed.

The ACK message is not returned for these commands and inquiries, and only the completion message of socket number 0 is returned.

Command execution cancel

To cancel a command which has already been sent, send the Cancel command as the next command. To cancel one of any two commands which have been sent, use the cancel message.

	Cancel Packet	Note
Cancel	8X 2Y FF	Y = socket number

X = 1 to 7: FCB-H11 address, Y = socket number

The Command canceled error message will be returned for this command, but this is not a fault. It indicates that the command has been canceled.

VISCA Device Setting Command

Before starting control of the FCB-H11, be sure to send the Address command and the IF_Clear command using the broadcast function.

For VISCA network administration

● Address

Sets an address of a peripheral device. Use when initializing the network, and receiving the following network change message.

● Network Change

Sent from the peripheral device to the controller when a device is removed from or added to the network. The address must be re-set when this message is received.

	Packet	Note
Address	88 30 01 FF	Always broadcasted.
Network Change	X0 38 FF	
X = 9 to F: FCB-H11 address + 8		

VISCA interface command

● IF_Clear

Clears the command buffers in the FCB-H11 and cancels the command currently being executed.

	Command Packet	Reply Packet	Note
IF_Clear	8X 01 00 01FF	Y0 50 FF	
IF_Clear (broadcast)	88 01 00 01 FF	88 01 00 01 FF	
X = 1 to 7: FCB-H11 address (For inquiry packet)			
Y = 9 to F: FCB-H11 address +8 (For reply packet)			

VISCA interface and inquiry

● CAM_VersionInq

Returns information on the VISCA interface.

Inquiry	Inquiry Packet	Reply Packet	Description
CAM_VersionInq	8X 09 00 02 FF	Y0 50 GG GG HH HH JJ JJ KK FF	GGGG: Vender ID (0020: Sony) HHHH = Model ID 044B: FCB-H11 JJJJ = ROM revision KK = Maximum socket # (02)

X = 1 to 7: FCB-H11 address (For inquiry packet)

Y = 9 to F: FCB-H11 address +8 (For reply packet)

VISCA Command/ACK Protocol

Command	Command Message	Reply Message	Comments
General Command	81 01 04 38 02 FF (Example)	90 41 FF (ACK)+90 51 FF (Completion) 90 42 FF 90 52 FF	Returns ACK when a command has been accepted, and Completion when a command has been executed.
	81 01 04 38 FF (Example)	90 60 02 FF (Syntax Error)	Accepted a command which is not supported or a command lacking parameters.
	81 01 04 38 02 FF (Example)	90 60 03 FF (Command Buffer Full)	There are two commands currently being executed, and the command could not be accepted.
	81 01 04 08 02 FF (Example)	90 61 41 FF (Command Not Executable) 90 62 41 FF	Could not execute the command in the current mode.
Inquiry Command	81 09 04 38 FF (Example)	90 50 02 FF (Completion)	ACK is not returned for the inquiry command.
	81 09 05 38 FF (Example)	90 60 02 FF (Syntax Error)	Accepted an incompatible command.
Address Set	88 30 01 FF	88 30 02 FF	Returned the device address to +1.
IF_Clear(Broadcast)	88 01 00 01 FF	88 01 00 01 FF	Returned the same command.
IF_Clear (For x)	8x 01 00 01 FF	z0 50 FF (Completion)	ACK is not returned for this command.
Command Cancel	8x 2y FF	z0 6y 04 FF (Command Canceled)	Returned when the command of the socket specified is canceled. Completion for the command canceled is not returned.
		z0 6y 05 FF (No Socket)	Returned when the command of the specified socket has already been completed or when the socket number specified is wrong.

VISCA Camera-Issued Messages

ACK/Completion Messages

	Command Messages	Comments
ACK	z0 4y FF (y:Socket No.)	Returned when the command is accepted.
Completion	z0 5y FF (y:Socket No.)	Returned when the command has been executed.

z = Device address + 8

Error Messages

	Command Messages	Comments
Syntax Error	z0 60 02 FF	Returned when the command format is different or when a command with illegal command parameters is accepted.
Command Buffer Full	z0 60 03 FF	Indicates that two sockets are already being used (executing two commands) and the command could not be accepted when received.
Command Canceled	z0 6y 04 FF (y:Socket No.)	Returned when a command which is being executed in a socket specified by the cancel command is canceled. The completion message for the command is not returned.
No Socket	z0 6y 05 FF (y:Socket No.)	Returned when no command is executed in a socket specified by the cancel command, or when an invalid socket number is specified.
Command Not Executable	z0 6y 41 FF (y:Execution command Socket No. Inquiry command:0)	Returned when a command cannot be executed due to current conditions. For example, when commands controlling the focus manually are received during auto focus.

Network Change Message

	Command Message	Comments
Network Change	z0 38 FF	Issued when power is being routed to the camera.

FCB-H11 Commands

FCB-H11 Command List (1/3)

Command Set	Command	Command Packet	Comments	
AddressSet	Broadcast	88 30 01 FF	Address setting	
IF_Clear	Broadcast	88 01 00 01 FF	I/F Clear	
CommandCancel		8x 2p FF	p: Socket No.(=1or2)	
CAM_Power	On	8x 01 04 00 02 FF	Power ON/OFF	
	Off	8x 01 04 00 03 FF		
CAM_Zoom	Stop	8x 01 04 07 00 FF	p=0 (Low) to 7 (High)	
	Tele(Standard)	8x 01 04 07 02 FF		
	Wide(Standard)	8x 01 04 07 03 FF		
	Tele(Variable)	8x 01 04 07 2p FF		
	Wide(Variable)	8x 01 04 07 3p FF		
	Direct	8x 01 04 47 0p 0q 0r 0s FF		pqrs: Zoom Position
CAM_DZoom	D-Zoom Limit	8x 01 04 26 0p FF	p=0 (x1), 1 (x1.5), 2 (x2), 3 (x4), 4 (x8), 5 (x12)	
CAM_Focus	Stop	8x 01 04 08 00 FF	p=0 (Low) to 7 (High)	
	Far(Standard)	8x 01 04 08 02 FF		
	Near(Standard)	8x 01 04 08 03 FF		
	Far(Variable)	8x 01 04 08 2p FF		
	Near(Variable)	8x 01 04 08 3p FF		
	Direct	8x 01 04 48 0p 0q 0r 0s FF		pqrs: Focus Position
	Auto Focus	8x 01 04 38 02 FF		AF ON/OFF
	Manual Focus	8x 01 04 38 03 FF		
	Auto/Manual	8x 01 04 38 10 FF		
	One Push Trigger	8x 01 04 18 01 FF		One Push AF Trigger
	Infinity	8x 01 04 18 02 FF		Forced infinity
Near Limit	8x 01 04 28 0p 0q 0r 0s FF	pqrs: Focus Near Limit Position		
CAM_AFMode	Normal AF	8x 01 04 57 00 FF	AF operation mode	
	Interval AF	8x 01 04 57 01 FF		
	ZOOM Trigger AF	8x 01 04 57 02 FF		
	Active/Interval Time	8x 01 04 27 0p 0q 0r 0s FF		pq: Active Time, rs: Interval
CAM_ZoomFocus	Direct	8x 01 04 47 0p 0q 0r 0s 0t 0u 0v 0w FF	pqrs: Zoom Position tuvw: Focus Position	
CAM_WB	Auto	8x 01 04 35 00 FF	Normal Auto	
	Indoor	8x 01 04 35 01 FF	Indoor mode	
	Outdoor	8x 01 04 35 02 FF	Outdoor mode	
	One Push WB	8x 01 04 35 03 FF	One Push WB mode	
	Manual	8x 01 04 35 05 FF	Manual Control mode	
	One Push Trigger ¹⁾	8x 01 04 10 05 FF	One Push WB Trigger	
CAM_RGain	Reset	8x 01 04 03 00 FF	Manual Control of R Gain	
	Up	8x 01 04 03 02 FF		
	Down	8x 01 04 03 03 FF		
	Direct	8x 01 04 43 00 00 0p 0q FF		pq: R Gain
CAM_BGain	Reset	8x 01 04 04 00 FF	Manual Control of B Gain	
	Up	8x 01 04 04 02 FF		
	Down	8x 01 04 04 03 FF		
	Direct	8x 01 04 44 00 00 0p 0q FF		pq: B Gain

FCB-H11 Command List (2/3)

Command Set	Command	Command Packet	Comments
CAM_AE	Full Auto	8x 01 04 39 00 FF	Full Auto
	Manual	8x 01 04 39 03 FF	Manual Control mode
	Shutter Priority	8x 01 04 39 0A FF	Shutter Priority Automatic Exposure mode
	Iris Priority	8x 01 04 39 0B FF	Iris Priority Automatic Exposure mode
	Bright	8x 01 04 39 0D FF	Bright Mode (Manual control)
	SpotLight	8x 01 04 39 10 FF	Spot light mode
CAM_SlowShutter	Auto	8x 01 04 5A 02 FF	AutoSlowShutter On/Off
	Manual	8x 01 04 5A 03 FF	
	AutoSlowShutterLimit	8x 01 04 2A 0p 00 FF	59.94 Hz system: p = 0 (1/60), 1 (1/30), 2 (1/15), 3 (1/8), 4 (1/4), 5 (1/2) 50 Hz system: p = 0 (1/50), 1 (1/25), 2 (1/12), 3 (1/6), 4 (1/3), 5 (1/2)
CAM_Shutter	Reset	8x 01 04 0A 00 FF	Shutter Setting
	Up	8x 01 04 0A 02 FF	
	Down	8x 01 04 0A 03 FF	
	Direct	8x 01 04 4A 00 00 0p 0q FF	pq: Shutter Position
CAM_Iris	Reset	8x 01 04 0B 00 FF	Iris Setting
	Up	8x 01 04 0B 02 FF	
	Down	8x 01 04 0B 03 FF	
	Direct	8x 01 04 4B 00 00 0p 0q FF	pq: Iris Position
CAM_Gain	Reset	8x 01 04 0C 00 FF	Gain Setting
	Up	8x 01 04 0C 02 FF	
	Down	8x 01 04 0C 03 FF	
	Direct	8x 01 04 4C 00 00 0p 0q FF	pq: Gain Position
CAM_Bright	Reset	8x 01 04 0D 00 FF	Bright Setting
	Up	8x 01 04 0D 02 FF	
	Down	8x 01 04 0D 03 FF	
	Direct	8x 01 04 4D 00 00 0p 0q FF	pq: Bright Position
CAM_ExpComp	On	8x 01 04 3E 02 FF	Exposure Compensation ON/OFF
	Off	8x 01 04 3E 03 FF	
	Reset	8x 01 04 0E 00 FF	Exposure Compensation Amount Setting
	Up	8x 01 04 0E 02 FF	
	Down	8x 01 04 0E 03 FF	
	Direct	8x 01 04 4E 00 00 0p 0q FF	pq: ExpComp Position
CAM_BackLight	On	8x 01 04 33 02 FF	Back Light Compensation ON/OFF
	Off	8x 01 04 33 03 FF	
CAM_SpotAE	On	8x 01 04 59 02 FF	Setting for Spot AE
	Off	8x 01 04 59 03 FF	
	Position	8x 01 04 29 0p 0q 0r 0s FF	pq: X (0 to F), rs: Y(0 to F)
CAM_Aperture	Reset	8x 01 04 02 00 FF	Aperture Control
	Up	8x 01 04 02 02 FF	
	Down	8x 01 04 02 03 FF	
	Direct	8x 01 04 42 00 00 0p 0q FF	pq: Aperture Gain
CAM_Gamma	Normal	8x 01 04 5B 00 FF	Gamma setting
	Cinema Type 1	8x 01 04 5B 01 FF	
	Cinema Type 2	8x 01 04 5B 02 FF	
CAM Freeze	On	8x 01 04 62 02 FF	Freeze On/Off
	Off	8x 01 04 62 03 FF	

FCB-H11 Command List (3/3)

Command Set	Command	Command Packet	Comments
CAM_PictureEffect	Off	8x 01 04 63 00 FF	Picture Effect Setting
	Neg.Art	8x 01 04 63 02 FF	
	B&W	8x 01 04 63 04 FF	
CAM_ICR	On	8x 01 04 01 02 FF	Infrared Mode On/Off
	Off	8x 01 04 01 03 FF	
CAM_AutoICR	On	8x 01 04 51 02 FF	Auto dark-field mode On/Off
	Off	8x 01 04 51 03 FF	
	Threshold	8x 01 04 21 00 00 0p 0q FF	pq: ICR ON → OFF Threshold Level
CAM_Memory	Reset	8x 01 04 3F 00 0p FF	p: Memory Number (=0 to 5)
	Set	8x 01 04 3F 01 0p FF	
	Recall	8x 01 04 3F 02 0p FF	
CAM_CUSTOM	Reset	8x 01 04 3F 00 7F FF	
	Set	8x 01 04 3F 01 7F FF	
	Recall	8x 01 04 3F 02 7F FF	
CAM_Mute	On	8x 01 04 75 02 FF	Mute On/Off
	Off	8x 01 04 75 03 FF	
	On/Off	8x 01 04 75 10 FF	
CAM_KeyLock	Off	8x 01 04 17 00 FF	Key operation enable/disable
	On	8x 01 04 17 02 FF	
CAM_IDWrite		8x 01 04 22 0p 0q 0r 0s FF	pqrs: Camera ID (=0000 to FFFF)
CAM_RegisterValue		8x 01 04 24 mm 0p 0q FF	mm: Register number (00 to 7F) pp: Register Value (00 to FF)

1) After an ACK to a One Push White Balance Trigger is sent until the operation is completed, "Not Executable" is sent as a reply when any other commands are received.

When a slow shutter speed (1/30, 1/25 or lower) is selected, the time needed for the One Push White Balance adjustment will be longer.

FCB-H11 Inquiry Command List (1/2)

Inquiry Command	Command Packet	Inquiry Packet	Comments
CAM_PowerInq	8x 09 04 00 FF	y0 50 02 FF	On
		y0 50 03 FF	Off
CAM_ZoomPosInq	8x 09 04 47 FF	y0 50 0p 0q 0r 0s FF	pqrs: Zoom Position
CAM_DZoomLimitInq	8x 09 04 26 FF	y0 50 0p FF	p= 0 (x1), 1 (x1/5), 2 (x2), 3 (x4), 4 (x8), 5 (x12)
CAM_FocusModeInq	8x 09 04 38 FF	y0 50 02 FF	Auto Focus
		y0 50 03 FF	Manual Focus
CAM_FocusPosInq	8x 09 04 48 FF	y0 50 0p 0q 0r 0s FF	pqrs: Focus Position
CAM_FocusNearLimitInq	8x 09 04 28 FF	y0 50 0p 0q 0r 0s FF	pqrs: Focus Near Limit Position
CAM_AFModeInq	8x 09 04 57 FF	y0 50 00 FF	Normal AF
		y0 50 01 FF	Interval AF
		y0 50 02 FF	Zoom Trigger AF
CAM_AFTimeSettingInq	8x 09 04 27 FF	y0 50 0p 0q 0r 0s FF	pq: Active Time, rs: Interval
CAM_WBModeInq	8x 09 04 35 FF	y0 50 00 FF	Auto
		y0 50 01 FF	In Door
		y0 50 02 FF	Out Door
		y0 50 03 FF	One Push WB
		y0 50 05 FF	Manual
CAM_RGainInq	8x 09 04 43 FF	y0 50 00 00 0p 0q FF	pq: R Gain
CAM_BGainInq	8x 09 04 44 FF	y0 50 00 00 0p 0q FF	pq: B Gain
CAM_AEModeInq	8x 09 04 39 FF	y0 50 00 FF	Full Auto
		y0 50 03 FF	Manual
		y0 50 0A FF	Shutter Priority
		y0 50 0B FF	Iris Priority
		y0 50 0D FF	Bright
		y0 50 10 FF	Spot Light
CAM_SlowShutterModeInq	8x 09 04 5A FF	y0 50 02 FF	Auto
		y0 50 03 FF	Manual
CAM_AutoSlowShutterLimitInq	8x 09 04 2A FF	y0 50 0p 00 FF	59.94 Hz system: p = 0 (1/60), 1 (1/30), 2 (1/15), 3 (1/8), 4 (1/4), 5 (1/2) 50 Hz system: p = 0 (1/50), 1 (1/25), 2 (1/12), 3 (1/6), 4 (1/3), 5 (1/2)
CAM_ShutterPosInq	8x 09 04 4A FF	y0 50 00 00 0p 0q FF	pq: Shutter Position
CAM_IrisPosInq	8x 09 04 4B FF	y0 50 00 00 0p 0q FF	pq: Iris Position
CAM_GainPosInq	8x 09 04 4C FF	y0 50 00 00 0p 0q FF	pq: Gain Position
CAM_BrightPosInq	8x 09 04 4D FF	y0 50 00 00 0p 0q FF	pq: Bright Position
CAM_ExpCompModeInq	8x 09 04 3E FF	y0 50 02 FF	On
		y0 50 03 FF	Off
CAM_ExpCompPosInq	8x 09 04 4E FF	y0 50 00 00 0p 0q FF	pq: ExpComp Position
CAM_BackLightModeInq	8x 09 04 33 FF	y0 50 02 FF	On
		y0 50 03 FF	Off
CAM_SpotAEModeInq	8x 09 04 59 FF	y0 50 02 FF	On
		y0 50 03 FF	Off
CAM_SpotAEPosInq	8x 09 04 29 FF	y0 50 0p 0q 0r 0s FF	pq: X position, rs: Y position
CAM_ApertureInq	8x 09 04 42 FF	y0 50 00 00 0p 0q FF	pq: Aperture Gain
CAM_GammaInq	8x 09 04 5B FF	y0 50 00 FF	Normal
		y0 50 01 FF	Cinema Type 1
		y0 50 02 FF	Cinema Type 2
CAM_FreezeModeInq	8x 09 04 62 FF	y0 50 02 FF	On
		y0 50 03 FF	Off

FCB-H11 Inquiry Command List (2/2)

Inquiry Command	Command Packet	Inquiry Packet	Comments
CAM_PictureEffectModeInq	8x 09 04 63 FF	y0 50 00 FF	Off
		y0 50 02 FF	Neg.Art
		y0 50 04 FF	B&W
CAM_MemoryInq	8x 09 04 3F FF	y0 50 pp FF	pp: Memory number last operated.
CAM_ICRModeInq	8x 09 04 01 FF	y0 50 02 FF	On
		y0 50 03 FF	Off
CAM_AutoICRModeInq	8x 09 04 51 FF	y0 50 02 FF	On
		y0 50 03 FF	Off
CAM_AutoICRThresholdInq	8x 09 04 21 FF	y0 50 00 00 0p 0q FF	pq: ICR ON → OFF Threshold Level
CAM_MuteModeInq	8x 09 04 75 FF	y0 50 02 FF	On
		y0 50 03 FF	Off
CAM_KeyLockInq	8x 09 04 17 FF	y0 50 00 FF	Off
		y0 50 02 FF	On
CAM_IDInq	8x 09 04 22 FF	y0 50 0p 0q 0r 0s FF	pqrs: Camera ID
CAM_VersionInq	8x 09 00 02 FF	y0 50 00 20 mn pq rs tu vw FF	mnpq: Model Code "(044A)" rstu: ROM version vw: Socket Number (=02) See page 21.
CAM_ReplyIntervalTimeInq	8x 09 04 6A FF	y0 50 00 00 0p 0p FF	pp: Interval Time
CAM_RegisterValueInq	8x 09 04 24 mm FF	y0 50 0p 0p FF	mm: Register number, pp: Register value

FCB-H11 Block Inquiry Command List

Lens control system inquiry commands Command Packet 8x 09 7E 7E 00 FF

Byte	Bit	Comments	Byte	Bit	Comments	Byte	Bit	Comments	
0	7	Destination Address	6	7	0	12	7	0	
	6			0	6		0		
	5			0	5		0		
	4			0	4		0		
	3	Source Address		3	Focus Near Limit (H)		3	0	
	2			2			0		
	1			1			0		
	0			0			0		
1	7	0 Completion Message (50h)	7	7	0		13	7	0
	6	1		6	0			6	0
	5	0		5	0			5	0
	4	1		4	0			4	AF Mode 0: Normal 1: Interval 2: Zoom Trigger
	3	0		3	Focus Near Limit (L)	3		0: Normal 1: Interval 2: Zoom Trigger	
	2	0		2		0		2	0
	1	0		1		0		1	1
	0	0		0		0		0	Focus Mode 1: Auto 0: Manual
2	7	0	8	7	0	14		7	0
	6	0		6	0			6	0
	5	0		5	0			5	0
	4	0		4	0			4	0
	3	Zoom Position (HH)		3	Focus Position (HH)		3	0	
	2			2			0		
	1			1			0		
	0			0			0		
3	7	0	9	7	0		15	7	1 Terminator (FFh)
	6	0		6	0			6	1
	5	0		5	0			5	1
	4	0		4	0			4	1
	3	Zoom Position (HL)		3	Focus Position (HL)	3		1	
	2			2		1			
	1			1		1			
	0			0		0			
4	7	0	10	7	0	15		3	1
	6	0		6	0			2	1
	5	0		5	0			1	1
	4	0		4	0			0	1
	3	Zoom Position (LH)		3	Focus Position (LH)		3	1	
	2			2			1		
	1			1			1		
	0			0			0		
5	7	0	11	7	0		15	7	0
	6	0		6	0			6	0
	5	0		5	0			5	0
	4	0		4	0			4	0
	3	Zoom Position (LL)		3	Focus Position (LL)	3		0	
	2			2		0			
	1			1		0			
	0			0		0			

Camera control system inquiry commands .. Command Packet 8x 09 7E 7E 01 FF

Byte	Bit	Comments	Byte	Bit	Comments	Byte	Bit	Comments		
0	7	Destination Address	6	7	0	12	7	0		
	6			0	6		0			
	5			0	5		0			
	4			OnePush RES	4		0			
	3	Source Address		3	0: Inquiring 1: OK 2: NG		3	Gain Position		
	2			WB Mode	2		0: Auto 1: Indoor 2: Outdoor		2	
	1				3: OnePush 5: Manual				1	0
	0			0			0			
1	7	0 Completion Message (50h)	7	7	0		13		7	0
	6	1		6	0				6	0
	5	0		5	0			5	0	
	4	1		4	0			4	Bright Position	
	3	0		3	Aperture Gain	3				
	2	0		2		0		2		
	1	0		1		0		1		
	0	0		0		0		0		
0	0	0								
2	7	0	8	7		0		14	7	0
	6	0		6	0	6			0	
	5	0		5	0	5			0	
	4	0		4	Exposure Mode 0x0: Auto 0x3: Manual 0xA: Shutter Pri 0xB: Iris Pri 0xD: Bright 0x10: SpotLight	4			0	
	3	R_Gain (H)		3		0x0: Auto 0x3: Manual	3		Exposure Comp. Position	
	2			0xA: Shutter Pri		2	0			
	1			0xB: Iris Pri 0xD: Bright		1	0			
	0			0x10: SpotLight		0	0			
0	0		0	0						
0	0		0							
3	7	0	9	7	0	15	7		1 Terminator (FFh)	
	6	0		6	0		6		1	
	5	0		5	0		5		1	
	4	0		4	0		4		1	
	3	R_Gain (L)		3	Spot AE 1: On 0: Off		3	1		
	2			Back Light 1:On 0:Off	2		1			
	1			Exposure Comp. 1:On 0:Off	1		1			
	0			Slow shutter 1: Auto 0: Manual	0		1			
0	0		0	1						
0	0		0	1						
4	7	0	10	7	0		11	7	0	
	6	0		6	0	6		0		
	5	0		5	0	5		0		
	4	0		4	Shutter Position	4		Iris Position		
	3	B_Gain (H)		3		0			3	
	2			0		2			0	
	1			0		1			0	
	0			0		0			0	
0	0		0	0						
0	0		0							
5	7	0	11	7	0	11		7	0	
	6	0		6	0		6	0		
	5	0		5	0		5	0		
	4	0		4	Iris Position		4	Iris Position		
	3	B_Gain (L)		3			0		3	
	2			0			2		0	
	1			0			1		0	
	0			0			0		0	
0	0		0	0						
0	0		0							

Other inquiry commands Command Packet 8x 09 7E 7E 02 FF

Byte	Bit	Comments
0	7	Destination Address
	6	
	5	
	4	
	3	Source Address
	2	
	1	
	0	
1	7	0 Completion Message (50h)
	6	1
	5	0
	4	1
	3	0
	2	0
	1	0
	0	0
2	7	0
	6	0
	5	0
	4	0
	3	0
	2	Auto ICR 1: On 0: Off
	1	Key Lock 1: On 0: Off
	0	Power 1: On 0: Off
3	7	0
	6	0
	5	0
	4	ICR 1: On 0: Off
	3	Freeze 1: On 0: Off
	2	0
	1	0
	0	0
4	7	0
	6	0
	5	0
	4	Mute 1: On 0: Off
	3	0
	2	0
	1	0
	0	0
5	7	0
	6	0
	5	0
	4	0
	3	Picture Effect Mode
	2	
	1	
	0	

Byte	Bit	Comments
6	7	0
	6	0
	5	0
	4	0
	3	0
	2	0
	1	Gamma Mode 0: Normal, 1: Cinema 1, 2: Cinema 2
	0	
7	7	0
	6	0
	5	0
	4	0
	3	0
	2	0
	1	0
	0	0
8	7	0
	6	0
	5	0
	4	0
	3	Camera ID (HH)
	2	
	1	
	0	
9	7	0
	6	0
	5	0
	4	0
	3	Camera ID (HL)
	2	
	1	
	0	
10	7	0
	6	0
	5	0
	4	0
	3	Camera ID (LH)
	2	
	1	
	0	
11	7	0
	6	0
	5	0
	4	0
	3	Camera ID (LL)
	2	
	1	
	0	

Byte	Bit	Comments
12	0	
	7	0
	6	0
	5	0
	4	Memory 1: Provided 0: Not
	3	0
	2	1
	1	0
0	System 1:50/PAL 0:59.94/NTSC	
13	7	0
	6	0
	5	0
	4	0
	3	0
	2	0
	1	0
	0	0
14	7	0
	6	0
	5	0
	4	0
	3	0
	2	0
	1	0
	0	0
15	7	1 Terminator (FFh)
	6	1
	5	1
	4	1
	3	1
	2	1
	1	1
	0	1

Enlargement Function Query Command Command Packet 8x 09 7E 7E 03 FF

Byte	Bit	Comments
0	7	Destination Address
	6	
	5	
	4	
	3	Source Address
	2	
	1	
	0	
1	7	0 Completion Message (50h)
	6	1
	5	0
	4	1
	3	0
	2	0
	1	0
	0	0
2	7	0
	6	0
	5	0
	4	0
	3	Digital Zoom Position (H)
	2	
	1	
	0	
3	7	0
	6	0
	5	0
	4	0
	3	Digital Zoom Position (L)
	2	
	1	
	0	
4	7	0
	6	0
	5	0
	4	0
	3	AF Activation Time (H)
	2	
	1	
	0	
5	7	0
	6	0
	5	0
	4	0
	3	AF Activation Time (L)
	2	
	1	
	0	

Byte	Bit	Comments
6	7	0
	6	0
	5	0
	4	0
	3	AF Interval Time (H)
	2	
	1	
	0	
7	7	0
	6	0
	5	0
	4	0
	3	AF Interval Time (L)
	2	
	1	
	0	
8	7	0
	6	0
	5	0
	4	0
	3	SpotAE Position (X)
	2	
	1	
	0	
9	7	0
	6	0
	5	0
	4	0
	3	SpotAE Position (Y)
	2	
	1	
	0	
10	7	0
	6	0
	5	0
	4	0
	3	0
	2	0
	1	0
	0	0
11	7	0
	6	0
	5	0
	4	0
	3	0
	2	0
	1	0
	0	0

Byte	Bit	Comments
12	7	0
	6	0
	5	0
	4	0
	3	0
	2	0
	1	0
	0	0
13	7	0
	6	0
	5	0
	4	0
	3	Auto Slow Shutter Limit
	2	
	1	
	0	
14	7	0
	6	0
	5	0
	4	0
	3	D-Zoom Limit
	2	
	1	
	0	
15	7	1 Terminator (FFh)
	6	1
	5	1
	4	1
	3	1
	2	1
	1	1
	0	1

VISCA Command Setting Values

Exposure Control (1/2)

		59.94/NTSC	50/PAL
Shutter Speed	15	10000	10000
	14	6000	6000
	13	4000	3500
	12	3000	2500
	11	2000	1750
	10	1500	1250
	0F	1000	1000
	0E	725	600
	0D	500	425
	0C	350	300
	0B	250	215
	0A	180	150
	09	125	120
	08	100	100
	07	90	75
	06	60	50
	05	30	25
	04	15	12
	03	8	6
	02	4	3
01	2	2	
Iris	11	F1.8	
	10	F2.0	
	0F	F2.4	
	0E	F2.8	
	0D	F3.4	
	0C	F4.0	
	0B	F4.8	
	0A	F5.6	
	09	F6.8	
	08	F8.0	
	07	F9.6	
	06	F11	
	05	F14	
	04	F16	
	03	F19	
	02	F22	
01	F26		
00	CLOSE		

Gain	07	18 dB
	06	15 dB
	05	12 dB
	04	9 dB
	03	6 dB
	02	3 dB
	01	0 dB
	00	-3 dB

Exposure Control (2/2)

		IRIS	GAIN
Bright	17	F1.8	18 dB
	16	F1.8	15 dB
	15	F1.8	12 dB
	14	F1.8	9 dB
	13	F1.8	6 dB
	12	F1.8	3 dB
	11	F1.8	0 dB
	10	F2.0	0 dB
	0F	F2.4	0 dB
	0E	F2.8	0 dB
	0D	F3.4	0 dB
	0C	F4.0	0 dB
	0B	F4.8	0 dB
	0A	F5.6	0 dB
	09	F6.8	0 dB
	08	F8.0	0 dB
	07	F9.6	0 dB
	06	F11	0 dB
	05	F14	0 dB
	04	F16	0 dB
03	F19	0 dB	
02	F22	0 dB	
01	F26	0 dB	
00	CLOSE	0 dB	

		Step	GAIN
Exposure Comp.	0E	+7	+10.5 dB
	0D	+6	+9 dB
	0C	+5	+7.5 dB
	0B	+4	+6 dB
	0A	+3	+4.5 dB
	09	+2	+3 dB
	08	+1	+1.5 dB
	07	0	0 dB
	06	-1	-1.5 dB
	05	-2	-3 dB
	04	-3	-4.5 dB
	03	-4	-6 dB
	02	-5	-7.5 dB
	01	-6	-9 dB
	00	-7	-10.5 dB

Zoom Ratio and Zoom Position (for HD reference)

Zoom Ratio	Position Data	D-Zoom Ratio
×1	0000	
×1.2	0800	
1.5	1000	
×1.9	1800	
×2.5	2000	
×3.4	2800	
×4.8	3000	
×6.8	3800	
×10.1	4000	
	4000	
	5bc0	×1.5
	69c0	×2
	7e80	×4
	8900	×8
	8c40	×12

Focus and Focus Distance (for HD reference)

Focus Position	1000: Over Inf to C000: 1.0 cm Far end Near end	
Focus Near Limit	1000: Over Inf. 2000: 4.5 m 3000: 2.0 m 4000: 1.2 m 5000: 80 cm 6000: 45 cm 7000: 38 cm 8000: 15 cm 9000: 7.0 cm A000: 3.8 cm B000: 2.1 cm C000: 1.0 cm	As the distance on the left will differ due to temperature characteristics, etc., use as approximate values. *The lower 1 byte is fixed at 00.

Others

AF Activation time	00 to FF
AF Interval time	00 to FF
Spot AE position (X)	00 to 0F
Spot AE position (Y)	00 to 0F
R gain	00 to FF
B gain	00 to FF
Aperture	00 to 0F
Auto ICR ON → OFF Threshold Level	00 to 1C

Register Setting

	Register No.	Value	
VISCA baurate	00	00	9600 bps
		01	19200 bps
		02	38400 bps (Initial setting)
Video signal	70	01	1080i/59.94 (Initial setting)
		02	720p/59.94
		03	NTSC (CROP)
		04	NTSC (SQ)
		11	1080i/50
		12	720p/50
		13	PAL (CROP)
		14	PAL (SQ)

Specifications

Effective picture elements	Approx. 2,000,000 pixels	Gain	Auto/Manual (−3 to +18 dB, 8 steps)
Video signal	HD: 1080i/59.94, 1080i/50, 720p/59.94, 720p/50 SD: NTSC (CROP), NTSC (SQUEEZE), PAL (CROP), PAL (SQUEEZE)	AE control	Full Auto/Shutter Priority/Iris Priority/Manual/Bright/Spot AE
Lens	10× zoom (F1.8 to F2.1) f= 5.1 mm (WIDE) to 51 mm (TELE) Zoom movement speed Optical WIDE/Optical TELE Approx. 1.0 sec Optical WIDE/Digital 4× TELE Approx. 1.5 sec Optical WIDE/Digital 4× TELE Approx. 0.5 sec Focus Movement time ∞ to Near Approx. 0.1 sec	Exposure compensation	± 10.5 dB (15 steps in a unit of 1.5 dB)
Digital zoom	12× (120× with optical zoom)	Backlight Compensation	ON/OFF
Angle of view (H)	Approx. 50 degree (WIDE end) to Approx. 5.4 degree (TELE end) (When an HD or SD (SQUEEZE) signal is output)	Gamma	Normal/Cinema Type 1/Cinema Type 2
Minimum object distance	10 mm (WIDE end), 800 mm (TELE end)	Auto ICR	ON/OFF (Auto/Manual)
Minimum illumination (Typical)	12 lux (F1.8) with 50 IRE 1.0 lux ICR On (F1.8) with 50 IRE	Picture effect	Black & white/Negative positive reversal, still image (frozen)
Recommended illumination	100 to 100,000 lux	Aperture control	16 steps
S/N ratio	50 dB or more	Preset	Position preset; 6 presets Custom preset; 1 preset
Electronic shutter speed	1/2 to 1/10000 sec. (21 steps)	Camera control interface	VISCA protocol (signal level:TTL/CMOS) Communication speed: 9.6 Kbps/19.2 Kbps/38.4 Kbps Bit length: 8 bits Stop bit: 1 bit
Focus	Full Auto (Normal AF/Interval AF/Zoom Trigger AF) One Push Trigger/Manual/Infinity/Near Limit setting	Video Output	HD: ANALOG COMPONENT (Y/Pb/Pr) SD: VBS, Y/C
White balance	Auto WB/Indoor/Outdoor/One Push WB/Manual WB	Storage temperature/Humidity	−20 to +60 °C (−4 to +140 °F)/20 to 95%
		Operating temperature/Humidity	0 to 45 °C (32 to 113 °F)/20 to 80%
		Power requirements/Power consumption	6 to 12 V DC/4.8 W
		Weight	120 g (2 lb 10 oz.)
		Dimensions	47.2× 43.1 × 72.2 mm (1 7/8 × 1 11/16 × 3 in.) (w/h/d) (Including the projecting parts)
		Supplied accessories	24-pin flexible flat cable (1)
		Design and specifications are subject to change without notice.	

Dimensions

Front

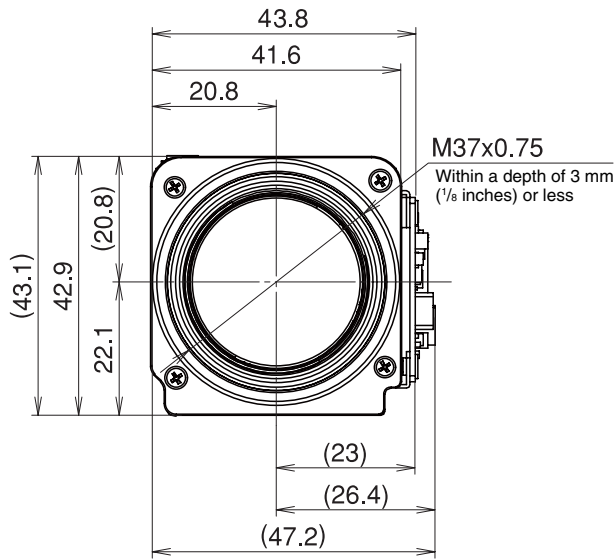

Back

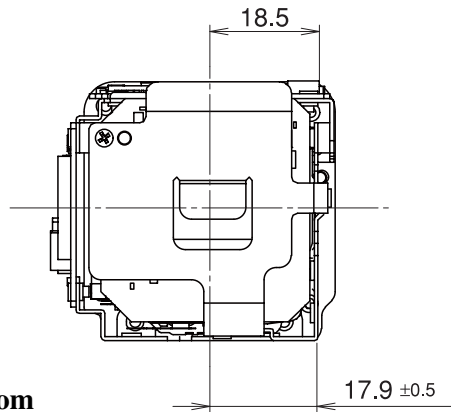

Bottom

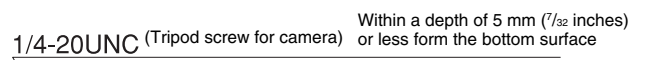

Top

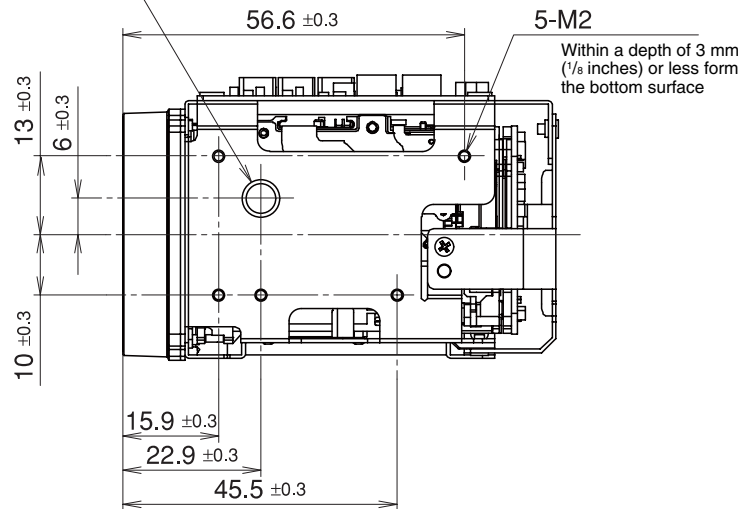
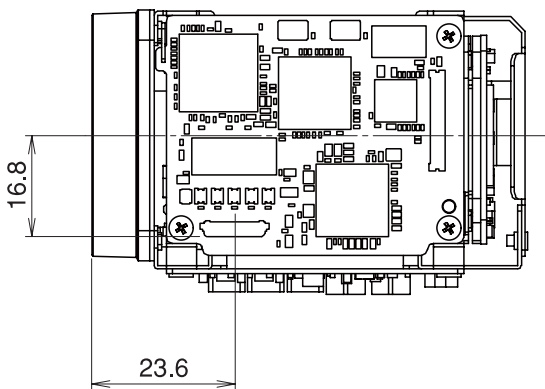

Left side

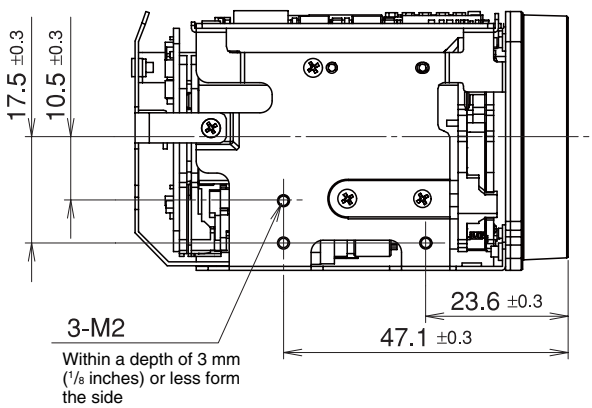

Right side

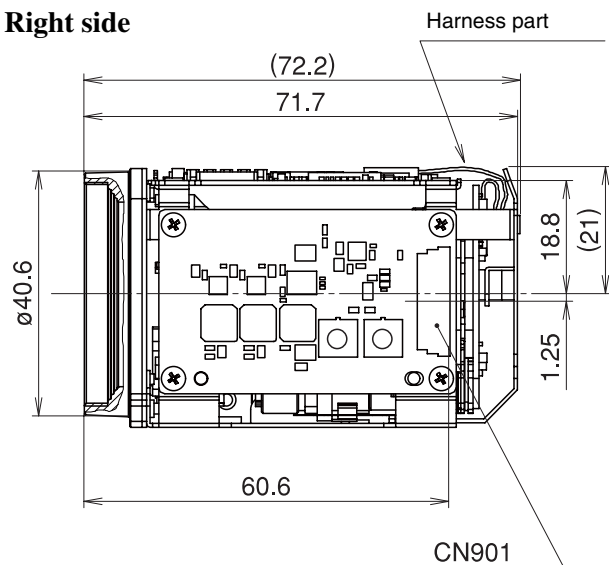

Unit: mm

Pin assignment

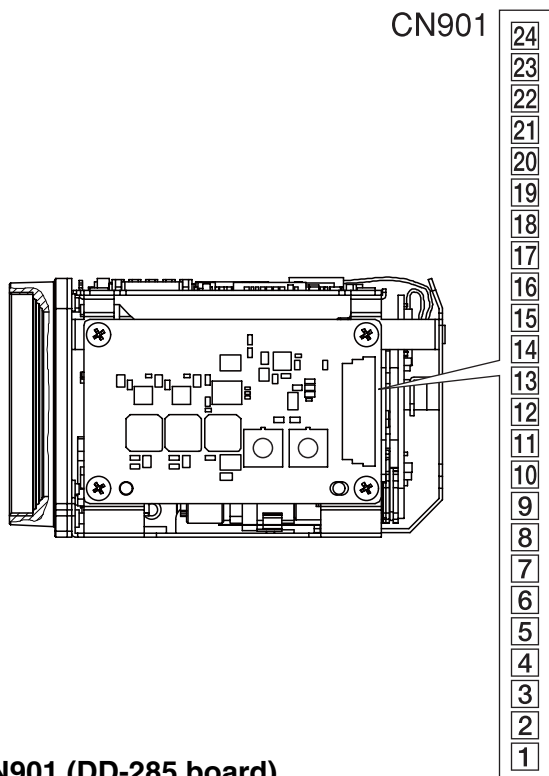

CN901 (DD-285 board)

KYOCERA ELCO Co. 04 6240 224 006 848+

Pin No.	Name	Level
1	GND	
2	TXD	CMOS 5V (low: max 0.1 V, high: min 2.4 V) Send Data
3	RXD	CMOS 5V (low: max 0.8 V, high: min 2.0 V) Received Data
4	RESET-IN	Reset:low (GND), Normal: Open (3.0 V)
5	GND	
6	Y OUT	
7	GND	
8	C_OUT	
9	GND	
10	VBS-OUT	
11	GND	
12	Y-OUT	
13	GND	
14	Pb-OUT	
15	GND	
16	Pr-OUT	
17	GND	
18	DC IN	9.0V±3.0 V
19	DC IN	9.0V±3.0 V
20	DC IN	9.0V±3.0 V
21	DC IN	9.0V±3.0 V
22	GND	
23	DC IN	9.0V±3.0 V
24	GND	