

# ***Color Camera Module***

---

## **Technical Manual**



**FCB-EX1010/EX1010P**

# Table of Contents

<b>Features .....</b>	<b>3</b>
<b>Precautions .....</b>	<b>4</b>
<b>Locations of Controls .....</b>	<b>5</b>
<b>Basic Functions .....</b>	<b>6</b>
Overview of Functions .....	6
Eclipse .....	19
Spectral Sensitivity Characteristics .....	19
Vibration Specifications .....	19
Key Switch Circuitry .....	20
Key Function Specifications .....	21
Initial Settings, Custom Preset and Backup .....	23
Mode Condition .....	25
<b>Command List .....</b>	<b>28</b>
VISCA/RS-232C Commands .....	28
FCB Camera Commands .....	34
<b>Specifications .....</b>	<b>50</b>

# Features

- The EX-view HAD™ CCD features 380,000 (NTSC) or 440,000 (PAL) effective picture elements and high-sensitivity shooting. The minimum illumination required is 1.4 lux ( $1/60$  s (NTSC),  $1/50$  s (PAL), ICR OFF).
- Images with a wide dynamic range can be obtained using the CCD for shooting with a dynamic range and the LSI system.
- 36× optical zoom (432× with digital zoom)
- Supporting external synchronization (V-lock)
- Images with a high resolution (530 TV lines) can be obtained using a newly developed DSP for improved picture quality.
- An infrared (IR) Cut-Filter can be disengaged from the image path for increased sensitivity in low light environments. The ICR will automatically engage depending on the ambient light, allowing the camera to be effective in day/night environment.
- VISCA is a communications protocol, which enables the camera to be controlled remotely from a host computer/controller.
- Six memory locations are provided to temporarily save and recall up to six sets of camera settings.
- Enhanced privacy zone masking (max. 24 blocks)
- A mosaic masking function has been added to the privacy zone masking function.
- A title composed of up to 11 lines can be set for displaying on the screen. 20 characters can be used on one line.
- E-FLIP function
- Alarm function with adjustable detection zones
- Adjustable AE response speed

With consideration given environmental protection, this module is designed to operate with low power consumption and also incorporates lead-free and halogen-free circuit boards.

# Precautions

---

## Software

Use of the demonstration software developed by Sony Corporation or use of the software with customer developed application software may damage hardware, the application program or the camera. Sony Corporation is not liable for any damages under these conditions.

---

## Operation

Start the camera control software on your computer after you turn on the camera and the image is displayed.

---

## Operation and storage locations

Do not shoot images that are extremely bright (e.g., light sources, the sun, etc.) for long periods of time. Do not use or store the camera in the following extreme conditions:

- Extremely hot or cold places (operating temperature 0 °C to +50 °C (32 °F to 122 °F))
- Close to generators of powerful electromagnetic radiation such as radio or TV transmitters
- Where it is subject to fluorescent light reflections
- Where it is subject to unstable (flickering, etc.) lighting conditions
- Where it is subject to strong vibration
- Where it is subject to radiation from laser beams

---

## Care of the unit

Remove dust or dirt on the surface of the lens with a blower (commercially available).

---

## Other

Do not apply excessive voltage. (Use only the specified voltage.) Otherwise, you may get an electric shock or a fire may occur.

In case of abnormal operation, contact your authorized Sony dealer or the store where you purchased the product.

---

## Phenomena specific to CCD image sensors

The following phenomena that may appear in images are specific to CCD (Charge Coupled Device) image sensors. They do not indicate malfunctions.

### White flecks

Although the CCD image sensors are produced with high-precision technologies, fine white flecks may be generated on the screen in rare cases, caused by cosmic rays, etc.

This is related to the principle of CCD image sensors and is not a malfunction.

The white flecks especially tend to be seen in the following cases:

- when operating at a high environmental temperature
- when you have raised the master gain (sensitivity)
- when operating in Slow-Shutter mode

### Vertical smear

When an extremely bright object, such as a strong spotlight or flashlight, is being shot, vertical tails may be produced on the screen, or the image may be distorted.

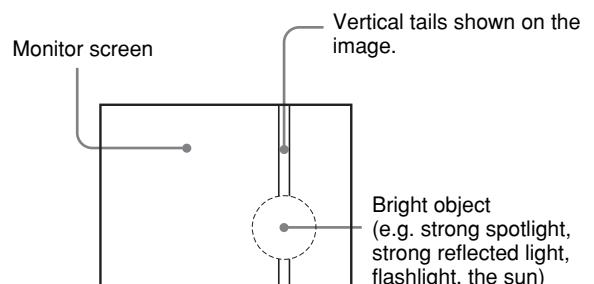

### Aliasing

When fine patterns, stripes, or lines are shot, they may appear jagged or flicker.

# Locations of Controls

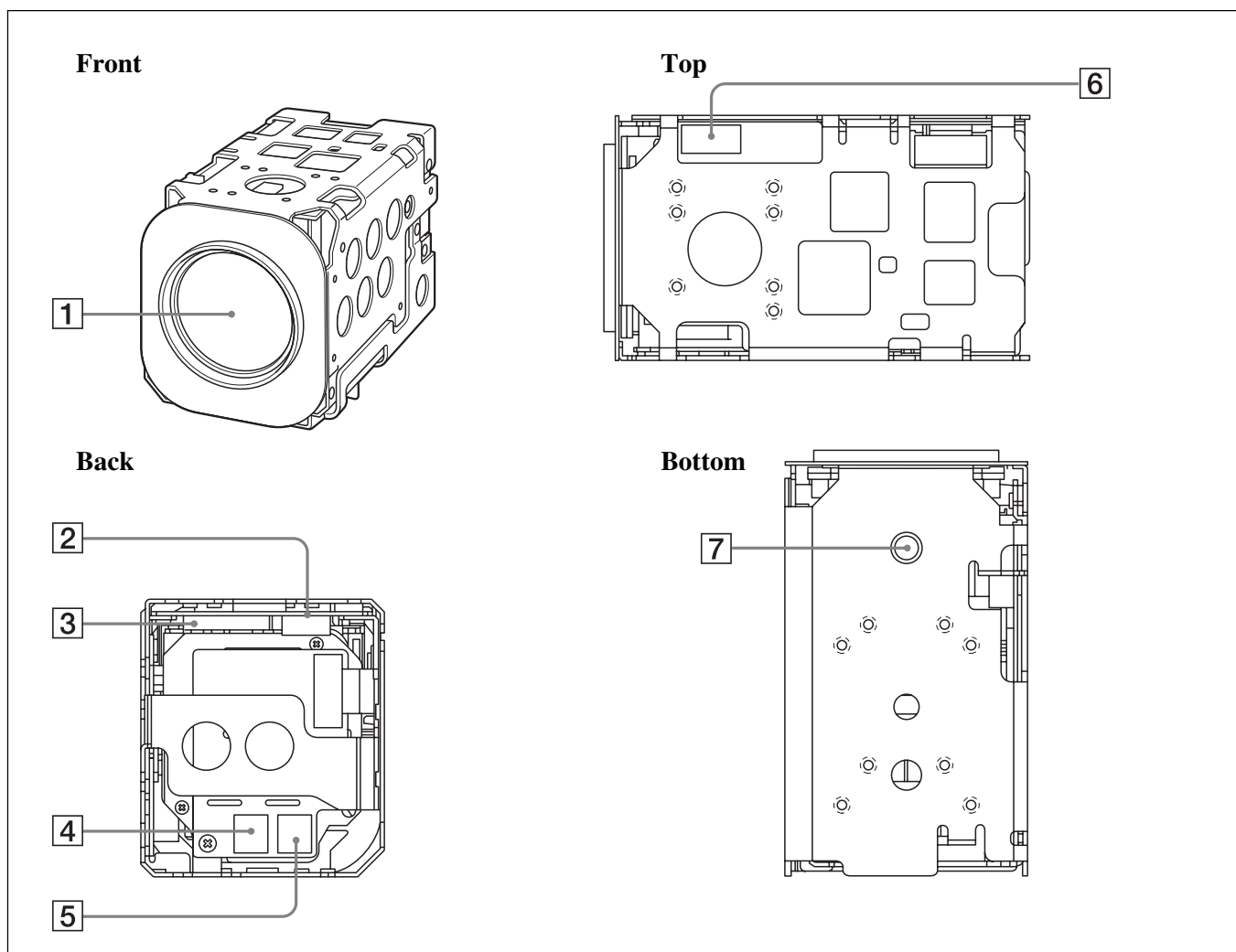

- 1 Lens
- 2 CN600 jack
- 3 CN601 jack

- 4 TELE button
- 5 WIDE button
- 6 CN702 jack (for key SW)

- 7 Tripod screw hole  
When a tripod is used, please use 7 mm ( $\frac{9}{32}$  in.) or less screw to attach it to the camera. Also, please be sure to attach the tripod securely.

# Basic Functions

## Overview of Functions

VISCA commands are the basis of camera control.

### Timing Chart

As VISCA Command processing can only be carried out one time in a Vertical cycle, it takes the maximum 1V cycle time for an ACK/Completion to be returned. If the Command ACK/Completion communication time can be cut shorter than the 1V cycle time, then every 1V cycle can receive a Command.

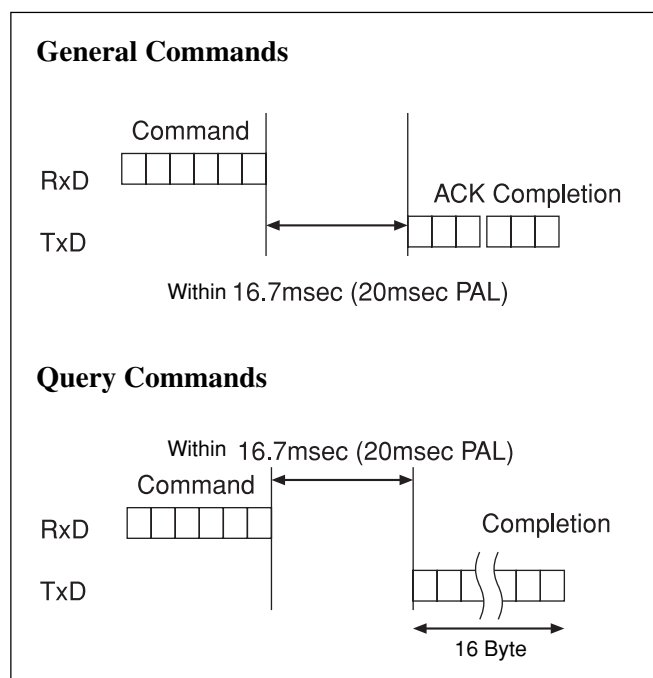

### In general

- **Power On/Off**  
Powers the camera on and off. When the power is off, the camera is able to accept only the lowest level of VISCA Commands; the display and other features are turned off.
- **I/F clear**  
Clears the Command buffer of the FCB camera. Clearing the buffer can also be carried out from the control application software when the power is on.
- **Address set**  
VISCA is a protocol, which normally can support a daisy chain of up to seven attached devices. In this case, if addresses from 1 to 7 are assigned to each of 7 devices, you can control seven cameras with the same personal computer. However, the FCB camera does not support connection of cameras in a daisy chain. Therefore, whenever a camera is connected for the first time, be sure to use the address set to confirm the address.
- **ID Write**  
Sets the camera ID.
- **Mute**  
Blanks the screen and sends out a synchronizing signal.
- **Lens Initialize**  
Initializes the zoom and focus of the lens. Even when power is already on, it initializes the zoom and the focus.
- **Comp Scan**  
A pixel blemish-masking feature, which can be made to reevaluate overall CCD pixel blemishes and mask severely flawed pixels automatically upon receiving the COMP SCAN command. This feature helps to mask the flaws found in CCD imagers, even after the camera has been powered on for some time.

---

## Zoom

The FCB camera employs a 36× optical zoom lens combined with a digital zoom function; this camera allows you to zoom up to 432×.

- **Optical 36×, f = 3.4 to 122.4 mm (F 1.6 to F 4.5)**

The horizontal angle of view is approximately 57.8 degrees (wide end) to 1.7 degrees (tele end). Digital Zoom enlarges the center of the subject by expanding each image in both the vertical and horizontal directions. When 432× zoom is used, the number of effective picture elements in each direction reduces to  $\frac{1}{12}$  and the overall resolution deteriorates.

You can activate the zoom in the following three ways

- **By pressing the TELE or WIDE buttons on the camera itself**

- **Using a VISCA Command**

- **Using Standard Mode**

- **Using Variable Mode**

- There are eight levels of zoom speed.

- **Direct Mode**

- Setting the zoom position enables quick movement to the designated position.

- **Digital Zoom ON/OFF**

- In these standard and variable Speed Modes, it is necessary to send Stop Command to stop the zoom operation.*

- The Zoom Mode supports a Combined Mode and a Separate Mode.

- **Combined Mode**

- This is the previously existing zoom method. After the optical zoom has reached its maximum level, the camera switches to Digital Zoom Mode.

- **Separate Mode**

- In this mode, Optical Zoom and Digital Zoom can be operated separately. You can use digital zoom magnification at any time from within any level of optical magnification.

- **Using an external key switch board connected to the CN702 jack.**

---

## Focus

Focus has the following modes, all of which can be set using VISCA Commands.

- **Auto Focus Mode**

The minimum focus distance is 320 mm at the optical wide end and 1500 mm at the optical tele end, and is independent of the digital zoom.

The Auto Focus (AF) function automatically adjusts the focus position to maximise the high frequency content of the picture in a center measurement area, taking into consideration the high luminance and strong contrast components.

- **Normal AF Mode**

- This is the normal mode for AF operations.

- **Interval AF Mode**

- The mode used for AF movements carried out at particular intervals. The time intervals for AF movements and for the timing of the stops can be set in one-second increments using the Set Time Command. The initial value for both is set to five seconds.

- **Zoom Trigger Mode**

- When the zoom is changed with the TELE or the WIDE buttons, the pre-set value (initially set at 5 seconds) becomes that for AF Mode. Then, it stops.

AF sensitivity can be set to either Normal or LOW.

- **Normal**

- Reaches the highest focus speed quickly. Use this when shooting a subject that moves frequently. Usually, this is the most appropriate mode.

- **LOW**

- Improves the stability of the focus. When the lighting level is low, the AF function does not take effect, even though the brightness varies, contributing to a stable image.

- **Manual Focus Mode**

Manual Focus has both a Standard Speed Mode and a Variable Speed Mode. Standard Speed Mode focuses at a fixed rate of speed. Variable Speed Mode has eight speed levels that can be set using a VISCA Command.

*In these standard and variable Speed Modes, it is necessary to send Stop Command to stop the zoom operation.*

- **One Push Trigger Mode**

When a Trigger Command is sent, the lens moves to adjust the focus for the subject. The focus lens then holds that position until the next Trigger Command is input.

- **Infinity Mode**

The lens is forcibly moved to a position suitable for an unlimited distance.

- **Near Limit Mode**

Can be set in a range from 1000 (∞) to C000 (10 mm).

## White Balance

White Balance has the following modes, all of which can be set using VISCA Commands.

- **Auto White Balance**

This mode computes the white balance value output using color information from the entire screen. It outputs the proper value using the color temperature radiating from a black subject based on a range of values from 3000 to 7500K.

This mode is the factory setting.

- **ATW**

Auto Tracing White balance (2000 to 10000 K)

- **Indoor**

3200 K Base Mode

- **Outdoor**

5800 K Base Mode

- **One Push WB**

The One Push White Balance mode is a fixed white balance mode that may be automatically readjusted only at the request of the user (One Push Trigger), assuming that a white subject, in correct lighting conditions, and occupying more than 1/2 of the image, is submitted to the camera.

One Push White Balance data is lost when the power is turned off. If the power is turned off, reset One Push White Balance.

- **Manual WB**

Manual control of R and B gain, 256 steps each

## Automatic Exposure Mode

A variety of AE functions are available for optimal output of subjects in lighting conditions that range from low to high.

- **Full Auto**

Auto Iris and Gain, Fixed Shutter Speed (NTSC: 1/60 sec., PAL: 1/50 sec.)

- **Shutter Priority**<sup>1)</sup>

Variable Shutter Speed, Auto Iris and Gain (1/1 to 1/10,000 sec., 16 high-speed shutter speeds plus 6 low-speed shutter speeds)

1) Flicker can be eliminated by setting shutter to

→ 1/100s for NTSC models used in countries with a 50 Hz power supply frequency

→ 1/120s for PAL models used in countries with a 60 Hz power supply frequency

- **Iris Priority**

Variable Iris (F1.6 to Close, 18 steps), Auto Gain and Shutter speed

- **Manual**

Variable Shutter, Iris and Gain

- **Bright**

Variable Iris and Gain (Close to F1.6, 17 steps at 0 dB: F1.6, 15 steps from 0 to 28 dB)

### AE – Shutter priority

The shutter speed can be set freely by the user to a total of 22 steps – 16 high speeds and 6 low speeds. When the slow shutter is set, the speed can be 1/30s, 1/15s, 1/8s, 1/4s, 1/2s, 1/1s. The picture output is read at a normal rate from the memory. The memory is updated at a low rate from the CCD. AF capability is low. In high speed mode, the shutter speed can be set up to 1/10,000s. The iris and gain are set automatically, according to the brightness of the subject.

Data	NTSC (s)	PAL (s)
15	1/10000	1/10000
14	1/6000	1/6000
13	1/4000	1/3500
12	1/3000	1/2500
11	1/2000	1/1750
10	1/1500	1/1250
0F	1/1000	1/1000
0E	1/725	1/600
0D	1/500	1/425
0C	1/350	1/300
0B	1/250	1/215
0A	1/180	1/150
09	1/125	1/120
08	1/100	1/100
07	1/90	1/75
06	1/60	1/50
05	1/30	1/25
04	1/15	1/12
03	1/8	1/6
02	1/4	1/3
01	1/2	1/2
00	1/1	1/1

### AE – Iris priority

The iris can be set freely by the user to 18 steps between F1.6 and Close.

The gain and shutter speed are set automatically, according to the brightness of the subject.

Data	Setting value	Data	Setting value
11	F1.6	08	F8
10	F2	07	F9.6
0F	F2.4	06	F11
0E	F2.8	05	F14
0D	F3.4	04	F16
0C	F4	03	F19
0B	F4.8	02	F22
0A	F5.6	01	F28
09	F6.8	00	CLOSE



**AE – Manual**

The shutter speed (22 steps), iris (18 steps) and gain (16 steps) can be set freely by the user.

**AE – Bright**

The bright control function adjusts both gain and iris using an internal algorithm, according to a brightness level freely set by the user. Exposure is controlled by gain when dark, and by iris when bright.

As both gain and iris are fixed, this mode is used when exposing at a fixed camera sensitivity. When switching from Full Auto or Shutter Priority Mode to Bright Mode, the current status will be retained for a short period of time.

Only when the AE mode is set to “Full Auto” or “Shutter Priority,” can you switch it to “Bright.”

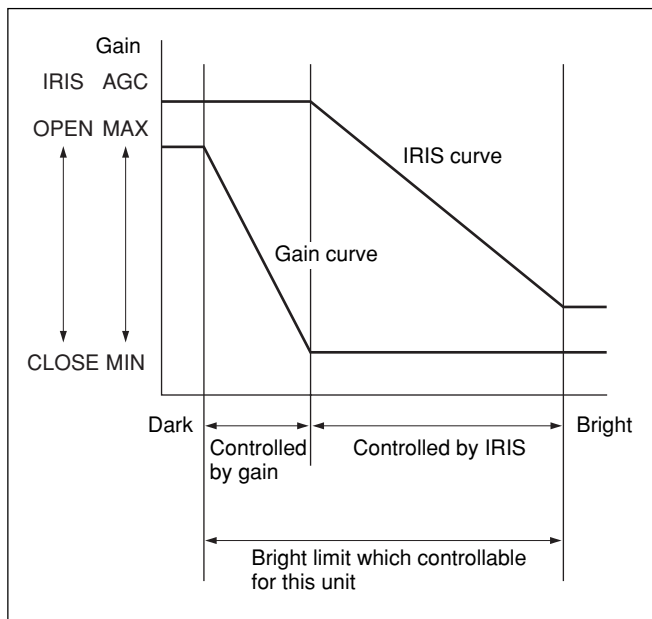

Data	Iris	Gain	Data	Iris	Gain
1F	F1.6	28 dB	0F	F2.4	0 dB
1E	F1.6	26 dB	0E	F2.8	0 dB
1D	F1.6	24 dB	0D	F3.4	0 dB
1C	F1.6	22 dB	0C	F4	0 dB
1B	F1.6	20 dB	0B	F4.8	0 dB
1A	F1.6	18 dB	0A	F5.6	0 dB
19	F1.6	16 dB	09	F6.8	0 dB
18	F1.6	14 dB	08	F8	0 dB
17	F1.6	12 dB	07	F9.6	0 dB
16	F1.6	10 dB	06	F11	0 dB
15	F1.6	8 dB	05	F14	0 dB
14	F1.6	6 dB	04	F16	0 dB
13	F1.6	4 dB	03	F19	0 dB
12	F1.6	2 dB	02	F22	0 dB
11	F1.6	0 dB	01	F28	0 dB
10	F2	0 dB	00	CLOSE	0 dB

When switching from the Shutter Priority mode to the Bright mode, the shutter speed set in the Shutter Priority mode is maintained.

**Spot Exposure Mode**

In Full Auto AE, the level for the entire screen is computed and the optimum Auto Iris and Gain levels are determined. In Spot AE, a particular section of the subject can be designated, and then that portion of the image can be weighted and a value computed so that Iris and Gain can be optimized to obtain an image. For example, in an image with a lot of movement and with varying levels of brightness, portions without much change can be designated as such a “spot,” and changes to the screen can be minimized in that area. As shown in the diagram below, a range of 16 blocks vertically and 16 blocks horizontally can be designated.

In the case where the center is designated (shown in black), the level is computed along with a weighted value for the surrounding block (shaded), including the specified portions; and then the Gain and Iris are set. The value of the designated portions and the surrounding areas should be calculated as 100%, the rest should be set to 20%. The range of the Spot AE frame is fixed to 5 blocks vertically and 4 blocks horizontally.

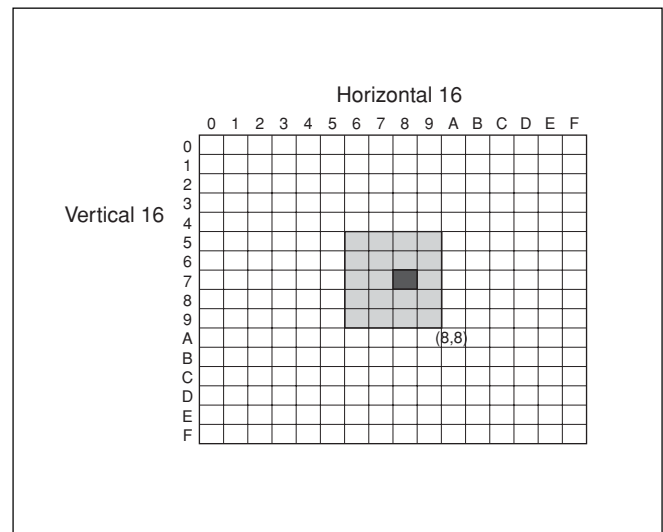

---

## Exposure Compensation

Exposure compensation is a function which offsets the internal reference brightness level used in the AE mode, by steps of 1.5 dB.

Data	Step	Setting value
0E	7	10.5 dB
0D	6	9 dB
0C	5	7.5 dB
0B	4	6 dB
0A	3	4.5 dB
09	2	3 dB
08	1	1.5 dB
07	0	0 dB
06	-1	-1.5 dB
05	-2	-3 dB
04	-3	-4.5 dB
03	-4	-6 dB
02	-5	-7.5 dB
01	-6	-9 dB
00	-7	-10.5 dB

---

## Slow AE (Automatic Exposure)

The slow AE Response (automatic exposure) function allows you to reduce the exposure response speed. Usually the camera is set up so that the optimum exposure can be obtained automatically within about 1 second. However, using the slow AE response function allows you to lengthen the automatic exposure response speed from the factory setup speed (01 (hex) up to 32 times (20 (hex))).

For example, with the normal setting (about 1 second), if the headlights of a car are caught by the camera, the camera automatically adjusts the exposure so that it can shoot a high-intensity subject (in this case, the headlights). As a result, images around the headlights, that is, the rest of the subject, except the headlights, becomes relatively dark, and poorly distinguished. However, using the slow AE function means the AE response speed will be slower, and response time will be longer. As a result, even if the camera catches a high-intensity subject (e.g., the headlights) for a moment, you can still easily distinguish the portions of the image surrounding the headlights.

---

## High Resolution Mode (Default)

A newly developed DSP function enables the filtering of signals. This allows the camera to provide images with a high resolution (530 TV lines).

When this function is set to OFF, the camera outputs images which are equivalent to 480 TV lines, just as with the FCB-EX1000/EX1000P camera.

---

## Aperture Control

Aperture control is a function which adjusts the enhancement of the edges of objects in the picture. There are 16 levels of adjustment, starting from “no enhancement.” When shooting text, this control may help by making them sharper.

---

## Back Light Compensation

When the background of the subject is too bright, or when the subject is too dark due to shooting in the AE mode, back light compensation will make the subject appear clearer.

---

## Wide Dynamic Range Mode

This function is effective when shooting images against the sun, or when shooting a very bright subject.

Using a CCD with a wide dynamic range and a newly developed DSP allows the camera to combine signals shot at a normal shutter speed and high intensity images shot at the high shutter speed.

The shutter speed automatically changes (1/1000 sec. to 1/8000 sec. Maximum  $\times 128$ ) depending on the level requested by high intensity images to obtain the best combined images.

### Note

When the wide dynamic mode is ON, some part of the image may appear solarised. This is normal for the wide dynamic mode, and is not a camera malfunction.

---

## Slow shutter – Auto/Manual

When set to “Auto,” ensures that the slow shutter is set automatically when the brightness drops. Effective only when the AE mode is set to “Full Auto.” Set to “Slow Shutter Manual” at shipment.

---

## ICR (IR Cut-Removable) Mode

An infrared (IR) Cut-Filter can be disengaged from the image path for increased sensitivity in low light environments. The ICR will automatically engage depending on the ambient light, allowing the camera to be effective in day/night environments.

When the auto ICR mode is set to ON, the image becomes black and white.

## Auto ICR Mode

Auto ICR Mode automatically switches the settings needed for attaching or removing the IR Cut Filter. With a set level of darkness, the IR Cut Filter is automatically disabled (ICR ON), and the infrared sensitivity is increased. With a set level of brightness, the IR Cut Filter is automatically enabled (ICR OFF). Also, on systems equipped with an IR light, the internal data of the camera is used to make the proper decisions to avoid malfunctions.

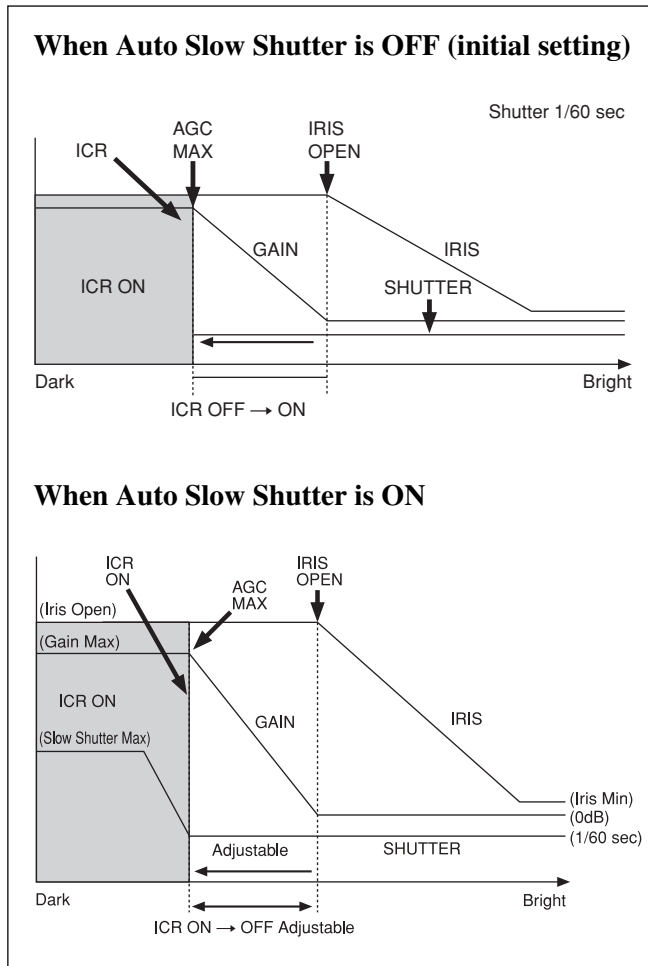

### Note

When in Auto\_ICR\_OFF state and WB data is added (default), a malfunction may occur when the subjects largely consisting of blue and green colors are taken.

## Camera ID

The ID can be set up to 65,536 (0000 to FFFF). As this will be memorized in the nonvolatile memory inside, data will be saved regardless of whether it has been backed up.

## Effect

It consists of the following functions.

- **Neg. Art:** Negative/Positive Reversal
- **Black White:** Monochrome Image

## Others

### E-FLIP

This function turns the video output from the camera upside down.

### Mirror image

This function reverses the video output from the camera horizontally.

### Freeze

This function captures an image in the field memory of the camera so that this image can be output continuously.

*Because communication inside the camera is based on V cycle, the captured image is always the one 3V to 4Vs after the sending of a Command. Thus, you can not specify a time period after sending EVEN, ODD or a Command.*

### Memory (Position preset)

Using the position preset function, 6 sets of camera shooting conditions can be stored and recalled.

This function allows you to achieve the desired status instantly, even without adjusting the following items each time.

- **Zoom Position**
- **Digital Zoom On/Off**
- **Focus Auto/Manual**
- **Focus Position**
- **AE Mode**
- **Shutter control parameters**
- **Bright Control**
- **Iris control parameters**
- **Gain control parameters**
- **Exposure Compensation On/Off**
- **Exposure Level**
- **Backlight Compensation On/Off**
- **Slow Shutter Auto/Manual**
- **Slow AE Response speed**
- **White Balance Mode**
- **R/B Gain**
- **Aperture**
- **ICR Shoot On/Off**

### Custom Preset

As with the position preset function, the camera shooting conditions can be stored and recalled. The settings are recalled when the power is turned on. *For setting items, see the "Initial Settings, Custom Preset and Backup" section on page 23.*

## User Memory Area

A user area of 16 bytes allows you to write data, such as an ID for each customer, data for each system, and so on, freely.

### Note

Rewriting of memory is not unlimited. Be careful to avoid using the memory area for such as unnecessary tasks as rewriting the contents of the memory for every operation.

## Privacy Zone Settings

For details, see page 13.

## Motion detection

For details, see page 17.

## Title Display

- You can set a title composed of up to 11 lines. One line can contain up to 20 characters.
- You can set display on/off, the horizontal position of the first character, blinking state and color for each line.
- The camera gives priority to lines of a title when the camera status is displayed on the relevant line. On the lines where a title is not set, the camera status is displayed.

Line Number	00 to 0A	
H-position	00 to 17	
Blink	00: Does not blink	
	01: Blinks	
Color	00	White
	01	Yellow
	02	Violet
	03	Red
	04	Cyan
	05	Green
	06	Blue

00	01	02	03	04	05	06	07
A	B	C	D	E	F	G	H
08	09	0a	0b	0c	0d	0e	0f
I	J	K	L	M	N	O	P
10	11	12	13	14	15	16	17
Q	R	S	T	U	V	W	X
18	19	1a	1b	1c	1d	1e	1f
Y	Z	&		?	!	1	2
20	21	22	23	24	25	26	27
3	4	5	6	7	8	9	0
28	29	2a	2b	2c	2d	2e	2f
À	È	Ì	Ò	Ù	Á	É	Í
30	31	32	33	34	35	36	37
Ó	Ú	Â	Ê	Ô	Æ	Œ	Ä
38	39	3a	3b	3c	3d	3e	3f
Õ	Ñ	Ç	ß	Ä	Ï	Ö	Ü
40	41	42	43	44	45	46	47
Å	\$	₹	¥	DM	£	ı	i
48	49	4a	4b	4c	4d	4e	4f
ø	“	:	‘	.	,	/	-

## Synchronization methods

Internal and external synchronization are available; VISCA Commands allow you to switch between them.

### • Internal synchronization

An internal vibrator inside the camera generates a synchronizing signal as a basic oscillator.  
 NTSC=28.636363MHz  
 PAL=17.7344MHz

### • External synchronization (V-Lock Synchronization <sup>1)</sup>)

When a TTL level V-Lock pulse is input, the camera synchronizes to the input signal (V-lock synchronization). The frequency of the input signal synchronizes to within  $\pm 1$ Hz of the external synchronization.

Also, 360 degree phase adjustment is possible due to the phase adjustment of the V-lock signal.

*Because V-lock synchronization is a simple synchronization method, color signals like a VBS “Genlock” signal cannot be synchronized.*

1) In V-lock synchronization, the camera makes a V-lock pulse (VL-PULSE) which synchronizes to the commercial power supply and uses it as the external synchronization input signal of the camera, using the fact that the V cycle (59.97 Hz vertical synchronization signal) and the frequency of the commercial power supply (60 Hz). The synchronous signal of the camera will automatically synchronizes to the VL-PULSE in the camera.

## Privacy Zone Masking Function

Privacy Zone masking protects private objects and areas such as house windows, entrances, and exits which are within the camera's range of vision but not subject to surveillance.

Privacy zone masking can be masked on the monitor to protect privacy.

### Features

- Mask can be set on up to 24 places according to Pan/Tilt positions.
- Mask can be displayed on 8 places per screen simultaneously.
- Privacy Zones are displayed according to priority in alphabetical order.
- Individual on/off zone masking settings.
- Two colors from among 29 colors including mosaic can be individually set for each of 24 privacy zones.
- Interlocking control with zooming.
- Interlocking control with Pan/Tilt.
- Non-interlocking control with Pan/Tilt.

#### Timing chart

8x 01 ... FF  
(Mask Setting Command)

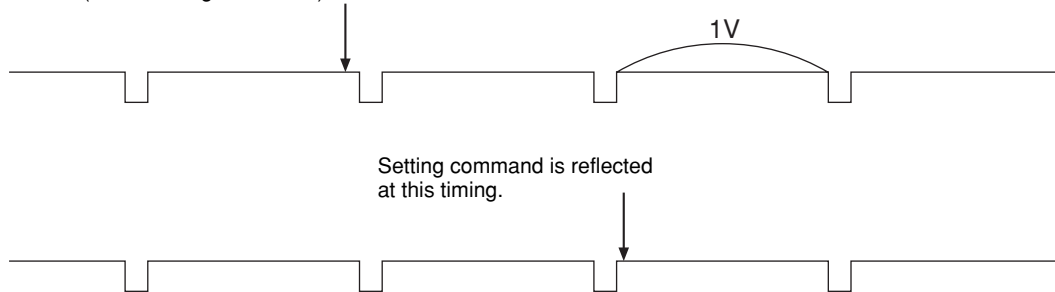

## Privacy Zone Setting Command List

Command Set	Command	Command Packet	Comments
CAM_PrivacyZone	SetMask	8x 01 04 76 mm nn 0r 0r 0s 0s FF	Setting Mask(Size) See “mm: Mask setting list”, “nn: Setting”, and “pp: x, qq:y, rr: w, ss: h” in “Parameters” on page 15.
	Display	8x 01 04 77 pp pp pp pp FF	Setting Mask Display On/Off See “pp pp pp pp: Mask bit” in “Parameters” on page 15. pp pp pp pp: Mask setting (0: OFF, 1: ON)
	SetMaskColor	8x 01 04 78 pp pp pp pp qq rr FF	Setting Color of Mask See “pp pp pp pp: Mask bit” and “qq, rr: Color code” in “Parameters” on page 15. qq: Color setting when setting the Mask bit to 0 rr: Color setting when setting the Mask bit to 1
	SetPanTiltAngle	8x 01 04 79 0p 0p 0p 0q 0q 0q FF	Setting Pan/Tilt Angle See “Setting pan/tilt angle” in “Parameters” on page 15. ppp: Pan angle, qq: Tilt angle
	SetPTZMask	8x 01 04 7B mm 0p 0p 0p 0q 0q 0q 0r 0r 0r FF	Setting the direct position of PTZ See “mm: Mask setting list” and “Setting pan/tilt angle” in “Parameters” on page 15. ppp: Pan , qq: Tilt , rrr: Zoom
	Non_InterlockMask	8x 01 04 6F mm 0p 0p 0q 0q 0r 0r 0s 0s FF	Setting non-interlocking the mask to pan/tilt See “mm: Mask setting list” and “pp:x, qq:y, rr:w, ss:h” in “Parameters” on page 15.
	Grid On	8x 01 04 7C 02 FF	Setting Grid Display On/Off
	Grid Off	8x 01 04 7C 03 FF	
	CenterLineOn	8x 01 04 7C 04 FF	Setting the center line On

## Privacy Zone Inquiry Command List

Inquiry Command	Command Packet	Inquiry Packet	Comments
CAM_PrivacyDisplayInq	8x 09 04 77 FF	y0 50 pp pp pp pp FF	Inquiry about the status of Setting Mask Display On/Off See “pp pp pp pp: Mask bit” in “Parameters” on page 15. 1:On, 0:Off
CAM_PrivacyPanTiltInq	8x 09 04 79 FF	y0 50 0p 0p 0p 0q 0q 0q FF	Inquiry about the pan/tilt position currently set See “Setting pan/tilt angle” in “Parameters” on page 15. ppp: Pan, qq: Tilt
CAM_PrivacyPTZInq	8x 09 04 7B mm FF	y0 50 0p 0p 0p 0q 0q 0q 0r 0r 0r 0r FF	Inquiry about pan/tilt/zoom position at the mm Mask setting See “mm: Mask setting list” and “Setting pan/tilt angle” in “Parameters” on page 15. ppp: Pan Position, qq: Tilt Position rrr: Zoom Position
CAM_PrivacyMonitorInq	8x 09 04 6F FF	y0 50 pp pp pp pp FF	Inquiry about the mask currently displayed See “pp pp pp pp: Mask bit” in “Parameters” on page 15.

## Parameters

### mm: Mask setting list

Mask Name	mm (Hex)
Mask_A	00h
Mask_B	01h
Mask_C	02h
Mask_D	03h
Mask_E	04h
Mask_F	05h
Mask_G	06h
Mask_H	07h
Mask_I	08h
Mask_J	09h
Mask_K	0Ah
Mask_L	0Bh

Mask Name	mm (Hex)
Mask_M	0Ch
Mask_N	0Dh
Mask_O	0Eh
Mask_P	0Fh
Mask_Q	10h
Mask_R	11h
Mask_S	12h
Mask_T	13h
Mask_U	14h
Mask_V	15h
Mask_W	16h
Mask_X	17h

### Note

The priority order of the mask display is in the sequence from A (highest) to X (lowest).

When you set the parameters of masks non-sequentially, it is recommended that you set the mask whose priority order is higher, first.

### nn:Setting

nn	Setting
00	Resetting the zone size (the value of w,h) for the existing mask.
01	Setting newly the zone size (the value of w,h).

### pp: x, qq: y, rr: w, ss: h

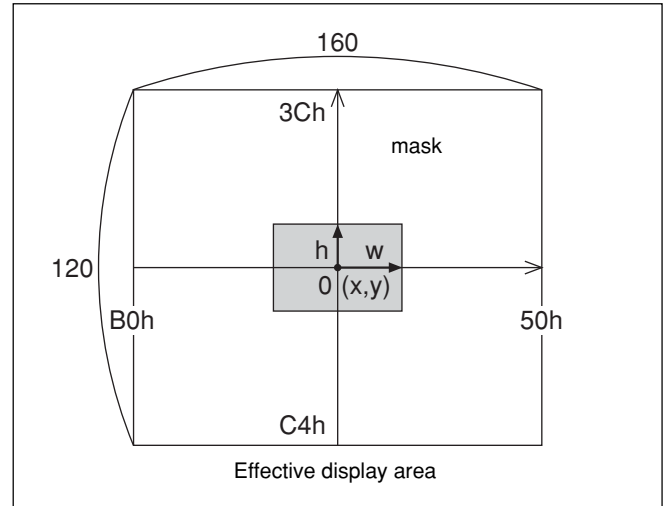

### pp pp pp pp: Mask bit

bit	pp								pp								pp								pp							
	7	6	5	4	3	2	1	0	7	6	5	4	3	2	1	0	7	6	5	4	3	2	1	0	7	6	5	4	3	2	1	0
Mask	-	-	X	W	V	U	T	S	-	-	R	Q	P	O	N	M	-	-	L	K	J	I	H	G	-	-	F	E	D	C	B	A

The "-" must be "0".

### qq, rr: Color code

Mask (Color)	Code (qq, rr)	Semi-transparency (qq, rr)
Black	00h	10h
Gray1	01h	11h
Gray2	02h	12h
Gray3	03h	13h
Gray4	04h	14h
Gray5	05h	15h
Gray6	06h	16h
White	07h	17h
Red	08h	18h
Green	09h	19h
Blue	0Ah	1Ah
Cyan	0Bh	1Bh
Yellow	0Ch	1Ch
Magenta	0Dh	1Dh
Mosaic	7Fh	-

### Setting pan/tilt angle

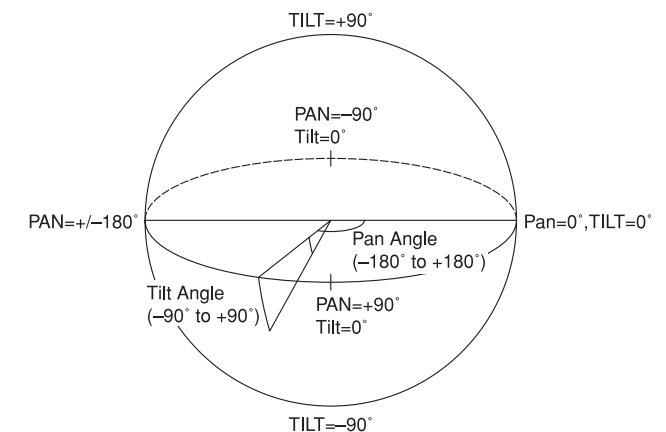
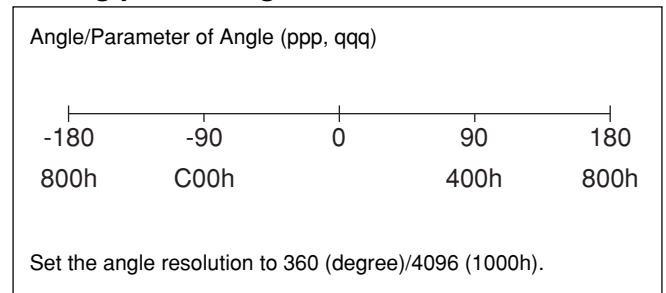

## Details of Setting Commands

### Set Mask

**Command:** 8x 01 04 76 mm nn Or Or Os Os FF

**Parameters:**

mm	Setting Mask See “mm: Mask setting list” in “Parameters” on page 15.
nn	Selects new setting or resetting for the zone. See “nn: Setting” in “Parameters” on page 15.
rr	Sets the half value “w” of the Mask Width.
ss	Sets the half value “h” of the Mask Height. See “pp: x, qq: y, rr: w, ss: h” in “Parameters” on page 15.

**Comments:** To set the mask, first display the object at the center of the screen. When “nn” is set to 1, the current Pan/Tilt/Zoom position is recorded in internal memory.

When “nn” is set to 0, the Pan/Tilt/Zoom position in memory is not changed.

#### Notes

- The tilt angle at which you can set the mask is between -70 to +70 degrees.
- It is recommended that you set the size to at least twice the size of the object (height and width).

### Set Display

**Command:** 8x 01 04 77 pp pp pp pp FF

**Parameter:**

pp pp pp pp	Each 24 Privacy Zones corresponds to 1 bit. See “pp pp pp pp: Mask bit” in “Parameters” on page 15.
-------------	--

**Comments:** Each of 24 Privacy zones can be switched on and off individually by a single VISCA command. If you want to display a Privacy zone, you must set its bit to 1. If you do not want to display a Privacy zone, you must set its bit to 0.

### Set Mask Color

**Command:** 8x 01 04 78 pp pp pp pp qq rr FF

**Parameter:**

pp pp pp pp	Each 24 Privacy Zones correspond with the BIT. See “pp pp pp pp: Mask bit” in “Parameters” on page 15.
qq	Set the color code include the semi-transparency code.
rr	Set the color code include the semi-transparency code. See “qq, rr: Color code” in “Parameters” on page 15.

**Comments:** Two different color masks can be chosen.

The colors can be chosen from among 14 colors including the possibility for semi-transparency of each color. Therefore two colors from among the total of 29 colors including mosaic can be individually set for each of 24 privacy zones.

If the bit of parameter (pp pp pp pp) is set to “0”, mask color will be “qq” color (Color code). If the bit of parameter (pp pp pp pp) is set to “1”, the mask color will be “rr” color (Color code).

**Example:** 8x 01 04 78 00 00 00 03 10 07 FF

The mask color of Mask\_A and Mask\_B is White (color code 07h), and the mask color of the other Mask (C to X) is semi-transparent Black (color code 10h).

### Set Pan Tilt Angle

**Command:** 8x 01 04 79 0p 0p 0p 0q 0q 0q FF

**Parameter:**

ppp	Pan Angle
qqq	Tilt Angle See “Setting pan/tilt angle” in “Parameters” on page 15.

**Comments:** Pan/Tilt angle settings are hexadecimal data.

The resolution of Pan/Tilt angle is 0.088 degrees.

#### Note

When you set the pan/tilt angle, locate the pan/tilt position at the center point of the FCB camera’s position.

### Set PTZ Mask

**Command:** 8x 01 04 7B mm 0p 0p 0p 0q 0q 0q 0r 0r Or Or FF

**Parameter:**

mm	Setting Mask See “mm: Mask setting list” in “Parameters” on page 15.
ppp	Pan Angle (000 to FFF) See “Setting pan/tilt angle” on page 15.
qqq	Tilt Angle (000 to FFF) See “Setting pan/tilt angle” on page 15.
rrrr	Zoom Position (000 to 4000) See “Zoom Ratio and Zoom Position (for reference)” on page 47.

**Comments:** Mask can be set at the desired position by setting the pan tilt angle and zoom position using this command. The set value can be input by hexadecimal number.



## Non Interlock Mask

**Command:** 8x 01 04 6F mm 0p 0p 0q 0q 0r 0r 0s 0s  
FF

### Parameters:

mm	Setting Mask See "mm: Mask setting list" in "Parameters" on page 15.
pp	Sets the center position "x" of the Mask on screen.
qq	Sets the center position "y" of the Mask on screen.
rr	Sets the half value "w" of the Mask Width.
ss	Sets the half value "h" of the Mask Height. See "pp: x, qq: y, rr: w, ss: h" in "Parameters" on page 15.

**Commands:** Mask does not interlock with pan/tilt.

The limitations of parameters are as follows.  
(hexadecimal representation)

x:  $\pm 50h$

w:  $\pm 50h$

y:  $\pm 3ch$

h:  $\pm 3ch$

### Note

When the Set Mask command and the Non Interlock Mask command are set to the same mask, the command set later becomes effective.

## Grid

Use the grid displayed on the screen to set mask positions (see the figure below).

By executing the Center Line On command, only the x and y axes of the center are displayed. Grids lines disappear.

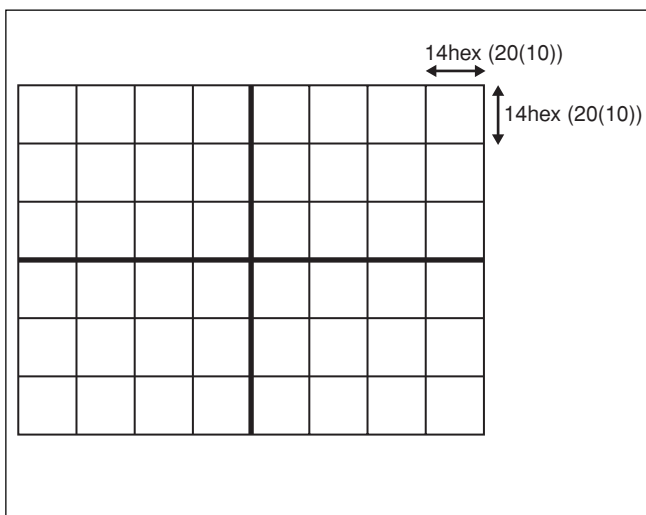

## Motion Detection Function

This function instructs the camera to detect movement within the monitoring area and then send an alarm signal automatically.

The Detect signal goes out through the serial command (VISCA) communication line.

### Features

- You can set a frame for the detection range of 12 (horizontally)  $\times$  8 (vertically) blocks.
- You can set up to four frames.
- When the motion is detected in the set frame, the Alarm Replay VISCA command is sent.
- The threshold level for detection can be set (common to four frames).
- The interval of alarm detection can be set up to 256 seconds in units of one second.
- You can set on/off for each frame.
- When the Block Mode is set to ON, the Alarm Reply command is not sent. Use this mode for checking when the camera is installed or for confirming the camera operation.
- The frame number is also sent with Alarm Replay to report in which frame the motion has been detected.

### Frames

#### Setting frames

You can set the frame by assigning the starting point and terminating point vertically and horizontally. You can set up to four frames.

#### When motion is detected within the range where frames overlap

The alarms are sent for both frames.

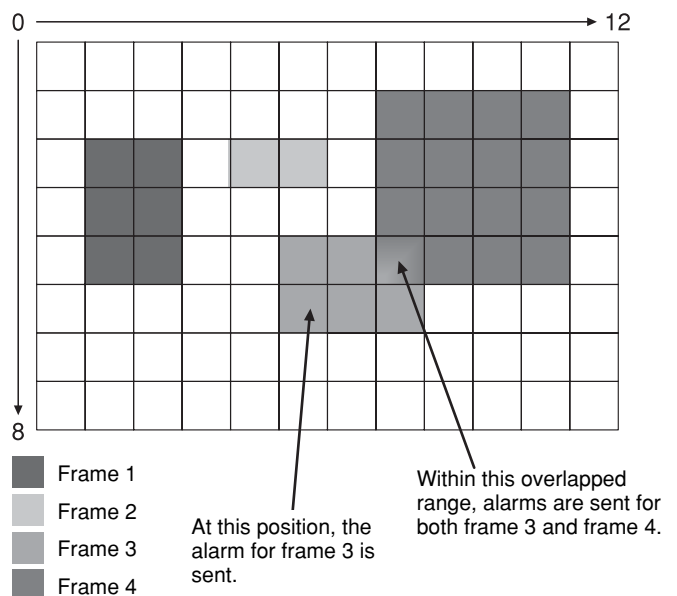

## Sending Alarms

- When motion is detected, the Alarm Replay command is issued via the serial command (VISCA) communication line.

- When multiple motions are detected or motion is detected in another frame within the set interval following the original time the alarm was issued, another alarm command is not issued.
- When motion is detected after the interval time elapsed, the alarm is issued again.

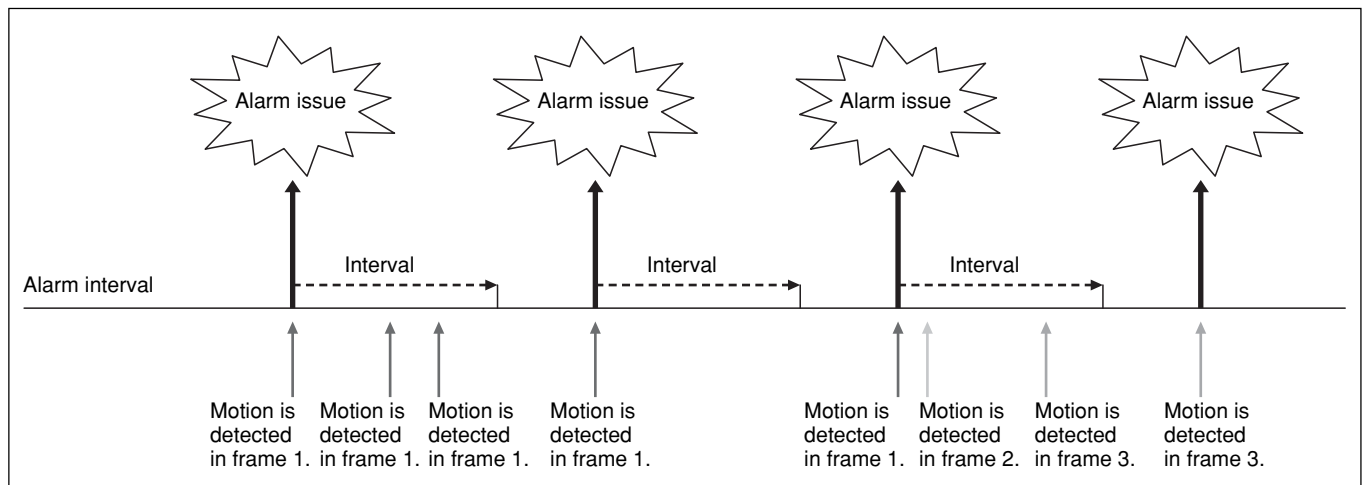

## Setting Commands

### • MD On/Off

The Display mode is selected by the Function Set command and frames are set by the Frame Set command. By sending an MD On command, the frame is displayed when motion is detected in the set frame. The Alarm Reply command is set via the serial command (VISCA) communication line.

```
8x 01 04 1B 02 FF --- On
8x 01 04 1B 03 FF --- Off
```

### • Function Set

The Display mode function has two modes. One is the Frame Mode, in which the detected frame is displayed on the screen, and the other is the Block Mode in which the block where the motion is detected is displayed from among the set of 12 (horizontally) × 8 (vertically) blocks. The Frame Mode is normally used. For examination and verification when the camera is installed, display blocks using the Block Mode. In the Block Mode, the Alarm Reply command is not sent.

```
8x 01 04 1C 0m 0n 0p 0q 0r 0s FF
m: Display Mode      on/off (bit0: Frame, bit1:
  Block)
n: Detection Frame set on/off (bit0:Frame0,
  bit1:Frame1, bit2:Frame2, bit3:Frame3)
  -- (0 to F)
pq: Threshold        -- (00 to FF)
rs: Interval time set -- (00 to FF)
(When pq and rs are 0, the command is received, but
the setting is disabled.)
```

### • Frame Set

You can set up to four frames by assigning the starting and terminating points.

#### Note

Set a terminating point higher vertically and horizontally than the starting point. If you set the wrong value, the command yields an error.

```
8x 01 04 1D 0m 0p 0q 0r 0s FF
```

```
m: Select Detection Frame (0: Frame0, 1: Frame1, 2:
  Frame2, 3: Frame3)      -- (0, 1, 2, 3)
p: Frame set Start Horizontal Position -- (00 to 0B)
q: Frame set Start Vertical Position  -- (00 to 07)
r: Frame set End Horizontal Position  -- (01 to 0C)
s: Frame set End Vertical Position    -- (01 to 08)
```

### • Alarm Reply

When motion is detected in the set frame, the camera issues this command. This command includes the information on the number of the detected frame.

```
y0 07 04 1B 0p FF
```

```
p: Frame Number (bit0: Frame0, bit1: Frame1, bit2:
  Frame2, bit3: Frame3)
```

# Eclipse

When designing the housing, refer to the dimensional allowance as shown in the figure below.

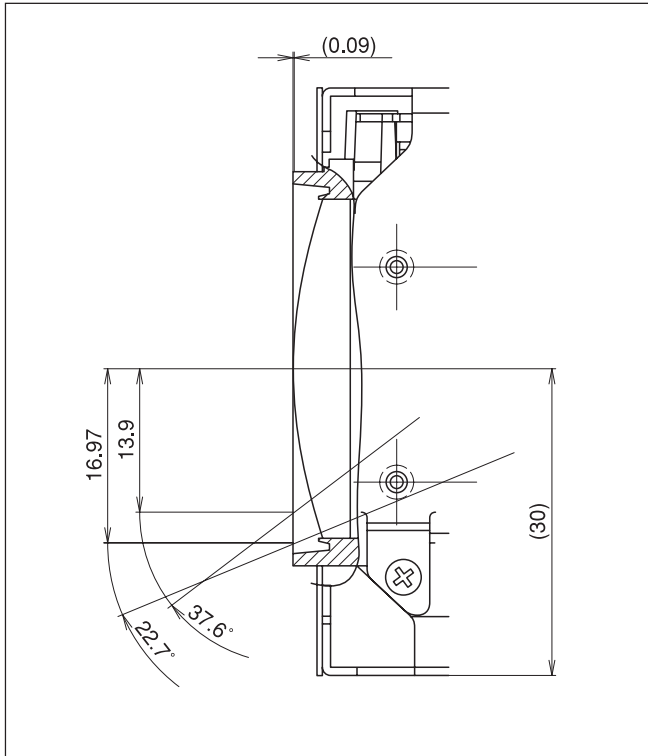

# Vibration Specifications

## Test Method (Random vibration)

- Fix the camera at the four fixation points of the base using M2 screws.
- Perform the random vibration test under the following conditions in the X, Y and Z directions for 20 minutes in each direction.
- The camera vibration specification is to have no malfunction after this test.

Power spectrum density	5 to 50 Hz	4.14 m <sup>2</sup> /s <sup>3</sup>	{0.043 G <sup>2</sup> /Hz}
	50 to 100 Hz	-36 dB/oct	
Effective overall value	14.3 m/s <sup>2</sup>		{1.46 G}
Test time	20 minutes		

# Spectral Sensitivity Characteristics

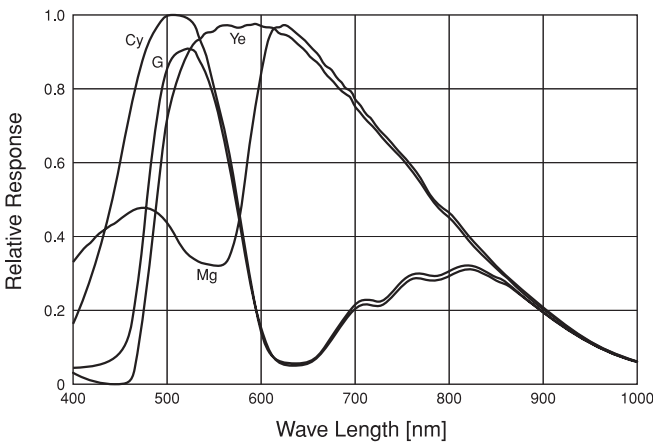

Use the graph as a reference value. (We can not guarantee these values.)  
 This data is measured when the IR cut filter is removed and the characteristics of the lens and optical source characteristics are ignored.



# Key Function Specifications

Classification	Name	Function	Button operation	Mode display
ZOOM	WIDE	Move ZOOM to WIDE side quickly.	Pressing repeatedly allowed.	ZOOM bar displayed for 3 s.
	WIDE SLOW	Move ZOOM to WIDE side slowly.	Pressing repeatedly allowed.	ZOOM bar displayed for 3 s.
	TELE SLOW	Move ZOOM to TELE side slowly.	Pressing repeatedly allowed.	ZOOM bar displayed for 3 s.
	TELE FAST	Move ZOOM to TELE side quickly.	Pressing repeatedly allowed.	ZOOM bar displayed for 3 s.
D-ZOOM	DZOOM	Turn on/off the mode for shifting from optical MAX to electronic ZOOM in combined mode.	Switch on/off.	ZOOM bar displayed for 3 s.
	DZOOM WIDE	Move the electronic ZOOM to WIDE side in separate mode.	Pressing repeatedly allowed.	ZOOM bar displayed for 3 s.
	DZOOM TELE	Move the electronic ZOOM to TELE side in separate mode.	Pressing repeatedly allowed.	ZOOM bar displayed for 3 s.
	DZOOM MAX	Switch the electronic ZOOM between 1× and MAX in separate mode.	Switch between 1× and MAX magnification.	ZOOM bar displayed for 3 s.
FOCUS	AF	Switch between Auto Focus and Manual Focus.	Switch between Auto and Manual.	Manual F indication
	NEAR	Move focus to NEAR side in Manual Focus mode.	Pressing repeatedly allowed.	Near indication
	FAR	Move focus to FAR side in Manual Focus mode.	Pressing repeatedly allowed.	Far indication
	ONE PUSH AF	Perform AF operation once in Manual Focus mode.	Request One Push AF.	Manual F indication flashes while request is made.
	INFINITY	Move focus forcibly to Infinity resulting in Manual Focus mode, regardless of the current focus mode.	Request Infinity.	Far indication
AE	AE AUTO	Switch to AE FULL Auto mode.	Request AE Full Auto.	No display
	BRIGHT	Switch to variable brightness mode (BRIGHT), depending on the conditions for mode shifting.	Request Bright mode. Pressing Up/Down key repeatedly allowed.	Bright bar display
	SHUTTER	Shutter priority AE mode	Request shutter priority AE mode.	Shutter code display
	IRIS	Iris priority AE mode	Request iris priority AE mode.	Iris code display
	BACK LIGHT	Switch backlight on/off.	Switch on/off.	Backlight indication
WB	AUTO WB	Switch to AUTO WB mode.	Request Auto WB mode.	No display
	ONE PUSH WB	Switch to One Push WB mode when pressed once and capture data when pressed 2nd time.	Request One Push WB mode and trigger.	One Push indication flashes at 0.8 Hz before capturing data, at 3.2 Hz during capturing, and stays lit after capturing.
	ATW	Switch to ATW mode.	Request ATW mode.	ATW display
	INDOOR	Enable WB at 3200K in INDOOR mode.	Request Indoor mode.	Indoor indication
	OUTDOOR	Enable WB at 5800K in OUTDOOR mode.	Request Outdoor mode.	Outdoor indication
	MANUAL WB	Switch to Manual WB mode. Enable R control when pressed once and enable B control when pressed 2nd time. Switchable with UP/DOWN key.	Switch between R control and B control in manual WB mode. Pressing Up/Down key repeatedly allowed.	“WB-MAN” (character display)

Classification	Name	Function	Button operation	Mode display
FEATURE	FREEZE	Capture still image.	Switch on/off.	FREEZE indication
	LR-REVERSE	Horizontal reversal	Switch on/off.	Horizontal reversal indication
	BLACK & WHITE	Black-and-white output	Switch on/off.	B&W display
	NEGA ART	Negative art output	Switch on/off.	Neg Art display
	MUTE	Mute video output	Switch on/off.	“MUTE” (character display)
DISPLAY	DISPLAY	Display	Switch on/off.	
	TITLE	Title setting	Request setting. → Setting is started with Exec. Pressing Up/Down key repeatedly allowed.	Title setting screen display
	EXEC	Confirm title setting.	Select with Up/Down and confirm with Exec.	Setting screen selection highlighted in yellow.
UP/DOWN	UP	Data UP key (priority for AE mode, Bright, manual WB, title, and clock)	Request UP.	Selection highlighted.
	DOWN	Data DOWN key (priority for AE mode, Bright, manual WB, title, and clock)	Request DOWN.	Selection highlighted.
PRESET	POS1	Recall preset position 1.	Request recall.	RECALL POS0
	POS2	Recall preset position 2.	Request recall.	RECALL POS1
	POS3	Recall preset position 3.	Request recall.	RECALL POS2
	POS4	Recall preset position 4.	Request recall.	RECALL POS3
	POS5	Recall preset position 5.	Request recall.	RECALL POS4
	POS6	Recall preset position 6.	Request recall.	RECALL POS5
	POS7	Recall custom preset.	Request recall.	RECALL
	POS PRESET	Write data. Enabled when pressed together with POS button.	Request setting. Enabled when pressed together with POS key.	PRESET display
POS RESET	Delete data. Enabled when pressed together with POS button.	Request deletion. Enabled when pressed together with POS key.	RESET display	
Others	APERTURE UP	Increase aperture (Aperture UP)	Request UP.	Aperture bar displayed for 3 s.
	AUTO SLOW SHUTTER	Switch Auto Slow Shutter on/off.	Switch on/off.	“ASS” (character display)
	APERTURE DOWN	Decrease aperture (Aperture DOWN)	Request DOWN.	Aperture bar displayed for 3 s.
	AF SENSITIVITY	Switch AF sensitivity between Normal and Low.	Switch between Normal and Low.	“SENS L” (character display)
	BRIGHT UP	Raise brightness setting (Bright UP) (When not in Bright mode, switching to Bright mode is made automatically depending on the conditions.)	Request UP./Pressing repeatedly allowed.	Bright bar display
	BRIGHT DOWN	Lower brightness setting (Bright DOWN) (When not in Bright mode, switching to Bright mode is made automatically depending on the conditions.)	Request DOWN./Pressing repeatedly allowed.	Bright bar display
	ICR ON/OFF	Switch ICR mode on/off	Switch on/off	

# Initial Settings, Custom Preset and Backup

Initial settings for the various functions of the FCB camera are indicated in the “Initial settings” column. The “Custom preset” column indicates whether the custom preset function can be used to store the settings. The function enables the stored settings to be recalled automatically when the camera is turned on. The “Back up at standby” column indicates whether the data is preserved even when the camera is powered OFF.

Mode/Position setting	Initial settings	Custom preset	Back up at standby
Zoom Position	Wide end	○	○
D-Zoom On/Off	On	○	○
D-Zoom Separate/Combine	Combine	○	○
D-Zoom Position	00h	○	○
Focus Position	—	○	○
Focus Auto/Manual	Auto	○	○
Near Limit Setting	8000h (32cm)	○	○
AF Sensitivity	Normal	○	○
AF Mode	Normal	○	○
AF Run Time	5 sec	○	○
AF Interval	5 sec	○	○
WB Mode	Auto	○	○
WB Data (Rgain, Bgain)	—	○	○
One Push WB Data	—	○	○
AE Mode	Full Auto	○	○
AE Response	01	○	○
WD On/Off	Off	○	○
Slow Shutter Mode	Manual	○	○
Shutter Position	1/60sec (NTSC), 1/50sec (PAL)	○	○
Iris Position	—	○	○
Gain Position	—	○	○
Bright Position	—	○	○
Exposure Compensation On/Off	Off	○	○
Exposure Compensation Amount	±0	○	○
BackLight On/Off	Off	○	○
Spot AE On/Off	Off	○	○
Spot AE Position Setting	X=8, Y=8	○	○
Aperture Level	6	○	○
High Resolution Mode On/Off	On	○	○
LR Reverse On/Off	Off	○	○
Freeze On/Off	Off	×	×
Picture Effect	Off	○	○
ICR On/Off	Off	○	○
Auto ICR On/Off	Off	○	○
Auto ICR Threshold Level	0Ah	○	○

A circle “○” in this column signifies that the data is preserved.

A cross “×” signifies that the data IS NOT preserved.

Mode/Position setting	Initial settings	Custom preset	Back up at standby
Camera Memory	Same as the initial value setting	○	○
Display On/Off	Off	○	○
Mute On/Off	Off	×	×
Title Display On/Off	Off	○	○
Title Setting	—	○	○
Mask Setting	—	○	○
Mask Display On/Off	Off	○	○
Mask Color Setting	—	○	○
Grid/Center Line Display On/Off	Off	○	○
Alarm On/Off	Off	○	○
Alarm Mode	—	○	○
Alarm Detect Level	—	○	○
E-Flip On/Off	Off	○	○
Privacy Zone On/Off	Off	○	○
Privacy Zone Setting	—	○	○
Key Lock On/Off	Off	○	○
Camera ID	0000h	○	○
External Lock Mode	Internal	○	○
V-Phase	Vsync edge position	○	○
Alarm DayLight Threshold Level	—	○	○
MD On/Off	Off	○	○
MD Display Setting	Off	○	○
MD Threshold Level	10h	○	○
MD Interval	1 sec	○	○
MD Window Setting	—	○	○
ZoomPos Continuous Output On/Off	Off	×	○
ZoomPos Continuous Output Interval	3Ch	×	○

A circle “○” in this column signifies that the data is preserved.

A cross “×” signifies that the data IS NOT preserved.

#### Note

The number of times written to EEPROM (when Custom Preset is executed) is limited.



# Mode Condition

## Condition

Mode	Power Off	Power On	Freeze On	MemRecall
Address Set	○	○	○	○
IF_Clear	○	○	○	○
Command Cancel	○	○	○	○
Power On/Off	○	○	○	○

## Lens

Mode	Power Off	Power On	Freeze On	MemRecall	Zoom Direct	Focus Direct	ZmFo Direct	Focus Auto
Zoom Tele/Wide/Stop	x	○	x	x	x	○	x	○
Zoom Direct	x	○	x	x	○	○	x	○
Zoom Focus Direct	x	○	x	x	x	x	○	x
D-Zoom On/Off	x	○	x	x	x	○	x	○
D-Zoom Separate/Combine	x	○	x	x	x	○	x	○
D-Zoom Tele/Wide/Stop	x	○	x	x	○	○	○	○
D-Zoom x1/Max	x	○	x	x	○	○	○	○
D-Zoom Direct	x	○	x	x	○	○	○	○
Focus Far/Near/Stop	x	○	x	x	○	x	x	x
Focus Direct	x	○	x	x	○	○	x	x
Focus Auto/Manual	x	○	x	x	○	x	x	○
One Push AF	x	○	x	x	○	x	x	x
Focus Infinity	x	○	x	x	○	x	x	○
Focus Near Limit	x	○	x	x	○	x	x	○
AF Sensitivity Normal/Low	x	○	x	x	○	○	○	○
AF Mode Norm/Interval/Zoom	x	○	x	x	○	○	○	○
AF Activation Time/Interval Setting	x	○	x	x	○	○	○	○
Camera Memory Set/Reset	x	○	○	x	x	x	x	○
Camera Memory Recall	x	○	○	○*	x	x	x	○
Lens Initialize	x	○	○	x	x	x	x	○
Comp Scan	x	○	○	x	x	x	x	○

\* x during recalling from key

## White Balance

Mode	Power Off	Initializing	Power On	Freeze On	MemRecall	WB AUTO	Indoor	Outdoor	OnePush	ATW	Manual
WB Mode Switchover	x	x	○	x	x	○	○	○	○	○	○
One Push WB	x	x	○	x	x	x	x	x	○	x	x
RGain Setting	x	x	○	x	x	x	x	x	x	x	○
BGain Setting	x	x	○	x	x	x	x	x	x	x	○

## Exposure

Mode	Power Off	Initializing	Power On	Freeze On	MemRecall	AE Full Auto	AE Manual	ShutterPri	Iris Priority	Bright
AE Full Auto	x	x	○	x	x	○	○	○	○	○
AE Manual	x	x	○	x	x	○	○	○	○	○
Shutter Priority	x	x	○	x	x	○	○	○	○	○
Iris Priority	x	x	○	x	x	○	○	○	○	○
Bright	x	x	○	x	x	○	x	○	x	○
Shutter Setting	x	x	○	x	x	x	○	○	x	x
Iris Setting	x	x	○	x	x	x	○	x	○	x
Gain Setting	x	x	○	x	x	x	○	x	x	x
Bright Setting	x	x	○	x	x	x	x	x	x	○
Slow Shutter Auto/Manual	x	x	○	x	x	○	○	○	○	○
Exposure Compensation On/Off	x	x	○	x	x	○	○	○	○	○
Exposure Compensation Setting	x	x	○	x	x	○	○	○	○	○
BackLight On/Off	x	x	○	x	x	○	x	x	x	x
SpotAE On/Off	x	x	○	x	x	○	○	○	○	○
SpotAE Setting	x	x	○	x	x	○	○	○	○	○
WD On/Off	x	x	○	○	○	○	○	○	○	○

## Others

Mode	Power Off	Initializing	Power On	Freeze On	MemRecall
Aperture Setting	x	x	○	x	x
High Resolution Mode On/Off	x	x	○	○	○
LR_Reverse On/Off	x	x	○	x	x
Freeze On/Off	x	x	○	○	x
Picture Effect Setting	x	x	○	x	x
ICR On/Off	x	x	○	x	x
Auto ICR On/Off	x	x	○	x	x
Auto ICR Threshold Level Setting	x	x	○	○	○
Display On/Off	x	x	○	○	○
Mute On/Off	x	x	○	○	○
Title Setting	x	x	○	○	○
Mask On/Off	x	x	○	○	○
Mask Setting	x	x	○	○	○
Key Lock On/Off	x	x	○	○	○
Alarm On/Off	x	x	○	○	○
Alarm Mode	x	x	○	○	○
MD On/Off	x	x	○	○	○
MD Function Setting	x	x	○	○	○
MD Window Setting	x	x	○	○	○
ID Write	x	x	○	○	○
Memory Save	x	x	○	○	○
Register Value Setting	x	x	○	○	○

## External Synchronization

Mode	Power Off	Initializing	Power On	Freeze On	MemRecall
External Lock Mode	x	x	○	○	○
V-Phase Up/Down/Stop/Reset	x	x	○	○	○
V-Phase Direct	x	x	○	○	○

# Command List

---

## VISCA<sup>1)</sup>/RS-232C Commands

This Manual outlines an RS-232 control protocol and command list for certain Sony cameras from which control software can be developed.

THIS CONTROL PROTOCOL AND COMMAND LIST IS PROVIDED BY SONY ON AN “AS-IS BASIS” WITHOUT WARRANTY OF ANY KIND. SONY DOES NOT WARRANT ANY PARTICULAR RESULT FROM THE USE OF THIS CONTROL PROTOCOL AND COMMAND LIST AND DISCLAIMS AND EXCLUDES ALL WARRANTIES. EXPRESS OR IMPLIED, WITH RESPECT TO THAT CONTROL PROTOCOL AND COMMAND LIST, INCLUDING, BUT NOT LIMITED TO, ANY OR ALL IMPLIED WARRANTIES OF MERCHANTABILITY OR FITNESS FOR A PARTICULAR PURPOSE. IN FACT, SONY SPECIFICALLY ACKNOWLEDGES THAT SOFTWARE DEVELOPED BASED ON THIS CONTROL PROTOCOL AND COMMAND LIST MAY CAUSE MALFUNCTION OR DAMAGE TO HARDWARE AND SOFTWARE USED WITH IT (INCLUDING SONY HARDWARE AND SOFTWARE) AND SPECIFICALLY DISCLAIMS ANY LIABILITY FOR ANY SUCH MALFUNCTION OR DAMAGE. THIS CONTROL PROTOCOL AND COMMAND LIST SHOULD BE USED WITH CAUTION.

## Overview of VISCA

In VISCA, the device outputting commands, for example, a computer, is called the controller. The device receiving the commands, an FCB camera is called the peripheral device. In VISCA, up to seven peripheral devices like the FCB camera can be connected to one controller using communication conforming to the RS-232C standard. The parameters of RS-232C are as follows.

- Communication speed: 9.6 kbps/19.2 kbps/38.4 kbps
- Data bits : 8
- Start bit : 1
- Stop bit : 1/2
- Non parity

Flow control using XON/XOFF and RTS/CTS, etc., is not supported.

---

1) VISCA is a protocol which controls consumer camcorders developed by Sony. “VISCA” is a trademark of Sony Corporation.

# VISCA Communication Specifications

## VISCA packet structure

The basic unit of VISCA communication is called a packet. The first byte of the packet is called the header and comprises the sender's and receiver's addresses. For example, the header of the packet sent to the FCB camera assigned address 1 from the controller (address 0) is hexadecimal 81H. The packet sent to the camera

assigned address 2 is 82H. In the command list, as the header is 8X, input the address of the camera at X. The header of the reply packet from the camera assigned address 1 is 90H. The packet from the camera assigned address 2 is A0H.

Some of the commands for setting cameras can be sent to all devices at one time (broadcast). In the case of broadcast, the header should be hexadecimal 88H.

When the terminator is FFH, it signifies the end of the packet.

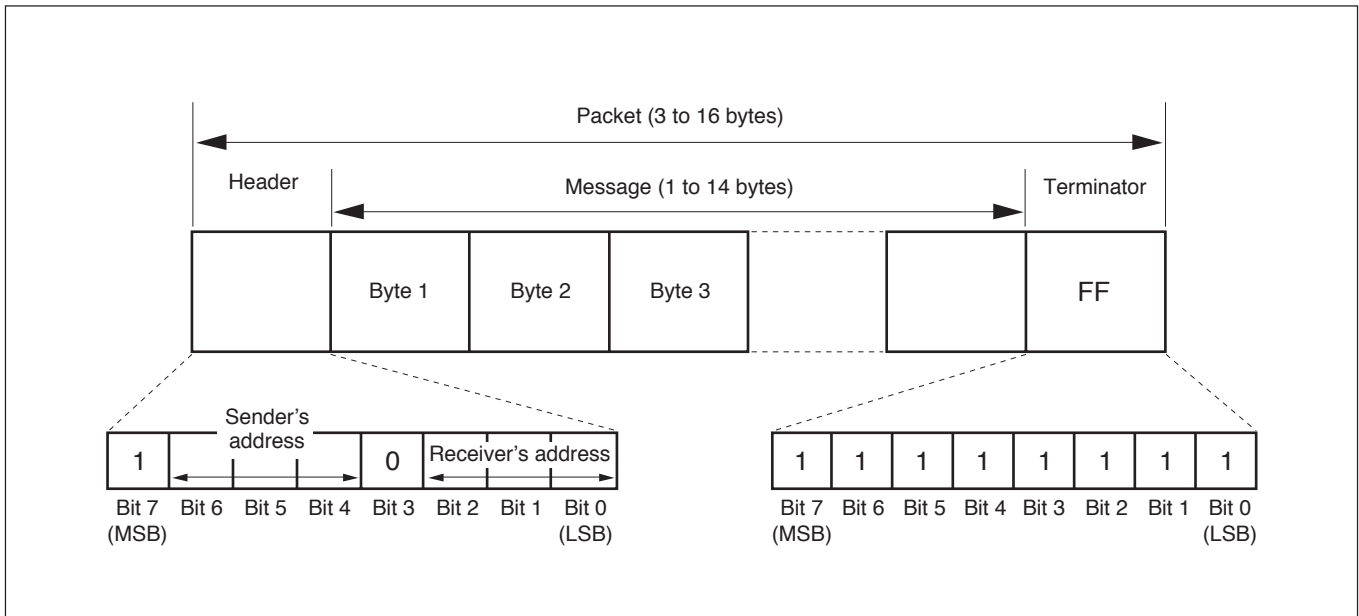

## Command and inquiry

- **Command**  
Sends operational commands to the FCB camera.
- **Inquiry**  
Used for inquiring about the current state of the FCB camera.

	Command Packet	Note
Inquiry	8X QQ RR ... FF	QQ <sup>1)</sup> = Command/Inquiry, RR <sup>2)</sup> = category code

<sup>1)</sup> QQ = 01 (Command), 09 (Inquiry)

<sup>2)</sup> RR = 00 (Interface), 04 (camera 1), 06 (Pan/Tilter), 07 (camera 2)

X = 1 to 7: FCB camera address

---

## Responses for commands and inquiries

### ● ACK message

Returned by the FCB camera when it receives a command. No ACK message is returned for inquiries.

### ● Completion message

Returned by the FCB camera when execution of commands or inquiries is completed. In the case of inquiry commands, it will contain reply data for the inquiry after the 3rd byte of the packet. If the ACK message is omitted, the socket number will contain 0.

	Reply Packet	Note
Ack	X0 4Y FF	Y = socket number
Completion (commands)	X0 5Y FF	Y = socket number
Completion (Inquiries)	X0 5Y ... FF	Y = socket number

X = 9 to F: FCB camera address + 8

### ● Error message

When a command or inquiry command could not be executed or failed, an error message is returned instead of the completion message.

Error Packet	Description
X0 6Y 01 FF	Message length error (>14 bytes)
X0 6Y 02 FF	Syntax Error
X0 6Y 03 FF	Command buffer full
X0 6Y 04 FF	Command cancelled
X0 6Y 05 FF	No socket (to be cancelled)
X0 6Y 41 FF	Command not executable

X = 9 to F: FCB camera address + 8, Y = socket number

---

## Socket number

When command messages are sent to the FCB camera, it is normal to send the next command message after waiting for the completion message or error message to return. However to deal with advanced uses, the FCB camera has two buffers (memories) for commands, so that up to two commands including the commands currently being executed can be received. When the FCB camera receives commands, it notifies the sender which command buffer was used using the socket number of the ACK message. As the completion message or error message also has a socket number, it indicates which command has ended. Even when two command buffers are being used at any one time, an FCB camera management command and some inquiry messages can be executed. The ACK message is not returned for these commands and inquiries, and only the completion message of socket number 0 is returned.

---

## Command execution cancel

To cancel a command which has already been sent, send the Cancel command as the next command. To cancel one of any two commands which have been sent, use the cancel message.

	Cancel Packet	Note
Cancel	8X 2Y FF	Y = socket number

X = 1 to 7: FCB camera address, Y = socket number

An error message will be returned for this command, but this is not a fault. It indicates that the command has been canceled.

## VISCA Device Setting Command

Before starting control of the FCB camera, be sure to send the Address command and the IF\_Clear command using the broadcast function.

---

### For VISCA network administration

#### ● Address

Sets an address of a peripheral device. Use when initializing the network, and receiving the following network change message.

#### ● Network Change

Sent from the peripheral device to the controller when a device is removed from or added to the network. The address must be re-set when this message is received.

	Packet	Note
Address	88 30 01 FF	Always broadcasted.
Network Change	X0 38 FF	
X = 9 to F: FCB camera address + 8		

---

### VISCA interface command

#### ● IF\_Clear

Clears the command buffers in the FCB camera and cancels the command currently being executed.

	Command Packet	Reply Packet	Note
IF_Clear	8X 01 00 01FF	X0 50 FF	
IF_Clear (broadcast)	88 01 00 01 FF	88 01 00 01 FF	
X = 1 to 7: FCB camera address (For inquiry packet)			
X = 9 to F: FCB camera address +8 (For reply packet)			

---

### VISCA interface and inquiry

#### ● CAM\_VersionInq

Returns information on the VISCA interface.

Inquiry	Inquiry Packet	Reply Packet	Description
CAM_VersionInq	8X 09 00 02 FF	Y0 50 GG GG HH HH JJ JJ KK FF	GGGG = Vender ID (0020: Sony) HHHH = Model ID 0444: FCB-EX1010 0445: FCB-EX1010P JJJJ = ROM revision KK = Maximum socket #(02)

X = 1 to 7: FCB camera address (For inquiry packet)

X = 9 to F: FCB camera address +8 (For reply packet)

## VISCA Command/ACK Protocol

Command	Command Message	Reply Message	Comments
General Command	81 01 04 38 02 FF (Example)	90 41 FF (ACK)+90 51 FF (Completion) 90 42 FF 90 52 FF	Returns ACK when a command has been accepted, and Completion when a command has been executed.
	81 01 04 38 FF (Example)	90 60 02 FF (Syntax Error)	Accepted a command which is not supported or a command lacking parameters.
	81 01 04 38 02 FF (Example)	90 60 03 FF (Command Buffer Full)	There are two commands currently being executed, and the command could not be accepted.
	81 01 04 08 02 FF (Example)	90 61 41 FF (Command Not Executable) 90 62 41 FF	Could not execute the command in the current mode.
Inquiry Command	81 09 04 38 FF (Example)	90 50 02 FF (Completion)	ACK is not returned for the inquiry command.
	81 09 05 38 FF (Example)	90 60 02 FF (Syntax Error)	Accepted an incompatible command.
Address Set	88 30 01 FF	88 30 02 FF	Returned the device address to +1.
IF_Clear(Broadcast)	88 01 00 01 FF	88 01 00 01 FF	Returned the same command.
IF_Clear (For x)	8x 01 00 01 FF	z0 50 FF (Completion)	ACK is not returned for this command.
Command Cancel	8x 2y FF	z0 6y 04 FF (Command Canceled)	Returned when the command of the socket specified is canceled. Completion for the command canceled is not returned.
		z0 6y 05 FF (No Socket)	Returned when the command of the specified socket has already been completed or when the socket number specified is wrong.



## VISCA Camera-Issued Messages

### ACK/Completion Messages

	Command Messages	Comments
ACK	z0 4y FF (y:Socket No.)	Returned when the command is accepted.
Completion	z0 5y FF (y:Socket No.)	Returned when the command has been executed.

z = Device address + 8

### Error Messages

	Command Messages	Comments
Syntax Error	z0 60 02 FF	Returned when the command format is different or when a command with illegal command parameters is accepted.
Command Buffer Full	z0 60 03 FF	Indicates that two sockets are already being used (executing two commands) and the command could not be accepted when received.
Command Canceled	z0 6y 04 FF (y:Socket No.)	Returned when a command which is being executed in a socket specified by the cancel command is canceled. The completion message for the command is not returned.
No Socket	z0 6y 05 FF (y:Socket No.)	Returned when no command is executed in a socket specified by the cancel command, or when an invalid socket number is specified.
Command Not Executable	z0 6y 41 FF (y:Socket No.)	Returned when a command cannot be executed due to current conditions. For example, when commands controlling the focus manually are received during auto focus.

### Network Change Message

	Command Message	Comments
Network Change	z0 38 FF	Issued when power is being routed.

# FCB Camera Commands

## Command List (1/5)

Command Set	Command	Command Packet	Comments
AddressSet	Broadcast	88 30 01 FF	Address setting
IF_Clear	Broadcast	88 01 00 01 FF	I/F Clesr
CommandCancel		8x 2p FF	p: Socket No.(=1or2)
CAM_Power	On	8x 01 04 00 02 FF	Power ON/OFF
	Off	8x 01 04 00 03 FF	
CAM_Zoom	Stop	8x 01 04 07 00 FF	p=0 (Low) to 7 (High)
	Tele(Standard)	8x 01 04 07 02 FF	
	Wide(Standard)	8x 01 04 07 03 FF	
	Tele(Variable)	8x 01 04 07 2p FF	
	Wide(Variable)	8x 01 04 07 3p FF	
	Direct	8x 01 04 47 0p 0q 0r 0s FF	
CAM_DZoom	On	8x 01 04 06 02 FF	Digital zoom ON/OFF
	Off	8x 01 04 06 03 FF	
	Combine Mode	8x 01 04 36 00 FF	Optical/Digital Zoom Combined
	Separate Mode	8x 01 04 36 01 FF	Optical/Digital Zoom Separate
	Stop	8x 01 04 06 00 FF	
	Tele(Variable)	8x 01 04 06 2p FF	p=0 (Low) to 7 (High)
	Wide(Variable)	8x 01 04 06 3p FF	
	x1/Max	8x 01 04 06 10 FF	x1/MAX Magnification Switchover
Direct	8x 01 04 46 00 00 0p 0q FF	pq: D-Zoom Position	
CAM_Focus	Stop	8x 01 04 08 00 FF	
	Far(Standard)	8x 01 04 08 02 FF	
	Near(Standard)	8x 01 04 08 03 FF	
	Far(Variable)	8x 01 04 08 2p FF	p=0 (Low) to 7 (High)
	Near(Variable)	8x 01 04 08 3p FF	
	Direct	8x 01 04 48 0p 0q 0r 0s FF	pqrs: Focus Position
	Auto Focus	8x 01 04 38 02 FF	AF ON/OFF
	Manual Focus	8x 01 04 38 03 FF	
	Auto/Manual	8x 01 04 38 10 FF	
	One Push Trigger	8x 01 04 18 01 FF	One Push AF Trigger
	Infinity	8x 01 04 18 02 FF	Forced infinity
Near Limit	8x 01 04 28 0p 0q 0r 0s FF	pqrs: Focus Near Limit Position	
AF Sensitivity	Normal	8x 01 04 58 02 FF	AF Sensitivity High/Low
	Low	8x 01 04 58 03 FF	
CAM_AFMode	Normal AF	8x 01 04 57 00 FF	AF Movement Mode
	Interval AF	8x 01 04 57 01 FF	
	Zoom Trigger AF	8x 01 04 57 02 FF	
	Active/Interval Time	8x 01 04 27 0p 0q 0r 0s FF	pq: Movement Time, rs: Interval
CAM_ZoomFocus	Direct	8x 01 04 47 0p 0q 0r 0s	pqrs: Zoom Position
		0t 0u 0v 0w FF	tuvw: Focus Position
CAM_Initialize	Lens	8x 01 04 19 01 FF	Lens Initialization Start
	Comp Scan	8x 01 04 19 02 FF	Correction of CCD pixel blemishes

## Command List (2/5)

Command Set	Command	Command Packet	Comments
CAM_WB	Auto	8x 01 04 35 00 FF	Normal Auto
	Indoor	8x 01 04 35 01 FF	Indoor mode
	Outdoor	8x 01 04 35 02 FF	Outdoor mode
	One Push WB	8x 01 04 35 03 FF	One Push WB mode
	ATW	8x 01 04 35 04 FF	Auto Tracing White Balance
	Manual	8x 01 04 35 05 FF	Manual Control mode
	One Push Trigger	8x 01 04 10 05 FF	One Push WB Trigger
CAM_RGain	Reset	8x 01 04 03 00 FF	Manual Control of R Gain
	Up	8x 01 04 03 02 FF	
	Down	8x 01 04 03 03 FF	
	Direct	8x 01 04 43 00 00 0p 0q FF	pq: R Gain
CAM_BGain	Reset	8x 01 04 04 00 FF	Manual Control of B Gain
	Up	8x 01 04 04 02 FF	
	Down	8x 01 04 04 03 FF	
	Direct	8x 01 04 44 00 00 0p 0q FF	pq: B Gain
CAM_AE	Full Auto	8x 01 04 39 00 FF	Automatic Exposure mode
	Manual	8x 01 04 39 03 FF	Manual Control mode
	Shutter Priority	8x 01 04 39 0A FF	Shutter Priority Automatic Exposure mode
	Iris Priority	8x 01 04 39 0B FF	Iris Priority Automatic Exposure mode
	Bright	8x 01 04 39 0D FF	Bright Mode (Manual control)
CAM_SlowShutter	Auto	8x 01 04 5A 02 FF	Auto Slow Shutter ON/OFF
	Manual	8x 01 04 5A 03 FF	
CAM_Shutter	Reset	8x 01 04 0A 00 FF	Shutter Setting
	Up	8x 01 04 0A 02 FF	
	Down	8x 01 04 0A 03 FF	
	Direct	8x 01 04 4A 00 00 0p 0q FF	pq: Shutter Position
CAM_Iris	Reset	8x 01 04 0B 00 FF	Iris Setting
	Up	8x 01 04 0B 02 FF	
	Down	8x 01 04 0B 03 FF	
	Direct	8x 01 04 4B 00 00 0p 0q FF	pq: Iris Position
CAM_Gain	Reset	8x 01 04 0C 00 FF	Gain Setting
	Up	8x 01 04 0C 02 FF	
	Down	8x 01 04 0C 03 FF	
	Direct	8x 01 04 4C 00 00 0p 0q FF	pq: Gain Position
CAM_Bright	Reset	8x 01 04 0D 00 FF	Bright Setting
	Up	8x 01 04 0D 02 FF	
	Down	8x 01 04 0D 03 FF	
	Direct	8x 01 04 4D 00 00 0p 0q FF	pq: Bright Position
CAM_ExpComp	On	8x 01 04 3E 02 FF	Exposure Compensation ON/OFF
	Off	8x 01 04 3E 03 FF	
	Reset	8x 01 04 0E 00 FF	Exposure Compensation Amount Setting
	Up	8x 01 04 0E 02 FF	
	Down	8x 01 04 0E 03 FF	
	Direct	8x 01 04 4E 00 00 0p 0q FF	
CAM_Backlight	On	8x 01 04 33 02 FF	Back Light Compensation ON/OFF
	Off	8x 01 04 33 03 FF	

## Command List (3/5)

Command Set	Command	Command Packet	Comments
CAM_AE_Response	DIRECT	8x 01 04 5D pp FF	pp: 01 to 20 (hex) Default value: 01
CAM_SpotAE	On	8x 01 04 59 02 FF	Spot Automatic Exposure Setting
	Off	8x 01 04 59 03 FF	
	Position	8x 01 04 29 0p 0q 0r 0s FF	
CAM_WD	On	8x 01 04 3D 02 FF	Wide-D ON/OFF
	Off	8x 01 04 3D 03 FF	
CAM_Aperture	Reset	8x 01 04 02 00 FF	Aperture Control
	Up	8x 01 04 02 02 FF	
	Down	8x 01 04 02 03 FF	
	Direct	8x 01 04 42 00 00 0p 0q FF	pp: Aperture Gain
CAM_HR	On	8x 01 04 52 02 FF	High-Resolution Mode ON/OFF
	Off	8x 01 04 52 03 FF	
CAM_LR_Reverse	On	8x 01 04 61 02 FF	Mirror Image ON/OFF
	Off	8x 01 04 61 03 FF	
CAM_Freeze	On	8x 01 04 62 02 FF	Still Image ON/OFF
	Off	8x 01 04 62 03 FF	
CAM_PictureEffect	Off	8x 01 04 63 00 FF	Picture Effect Setting
	Neg.Art	8x 01 04 63 02 FF	
	B&W	8x 01 04 63 04 FF	
CAM_PictureFlip	On	8x 01 04 66 02 FF	Picture flip ON/OFF
	Off	8x 01 04 66 03 FF	
CAM_ICR	On	8x 01 04 01 02 FF	Infrared Mode ON/OFF
	Off	8x 01 04 01 03 FF	
CAM_AutoICR	On	8x 01 04 51 02 FF	Auto dark-field mode On/Off
	Off	8x 01 04 51 03 FF	
	Threshold	8x 01 04 21 00 00 0p 0q FF	
CAM_Memory	Reset	8x 01 04 3F 00 0p FF	p: Memory Number (=0 to 5)
	Set	8x 01 04 3F 01 0p FF	
	Recall	8x 01 04 3F 02 0p FF	
CAM_Custom	Reset	8x 01 04 3F 00 7F FF	Starts in this mode at Power ON.
	Set	8x 01 04 3F 01 7F FF	
	Recall	8x 01 04 3F 02 7F FF	
CAM_MemSave	Write	8x 01 04 23 0X 0p 0p 0q 0q FF	X:00 to 07 (Address) Total 16 Byte ppqq: 0x0000 to 0xFFFF (Data)
CAM_Display	On	8x 01 04 15 02 FF (8x 01 06 06 02 FF)	Display ON/OFF
	Off	8x 01 04 15 03 FF (8x 01 06 06 03 FF)	
	On/Off	8x 01 04 15 10 FF (8x 01 06 06 10 FF)	

## Command List (4/5)

Command Set	Command	Command Packet	Comments
CAM_Title	Title Set1	8x 01 04 73 1L 00 nn pp qq rr 00 00 00 00 FF	L: Line Number, nn: H-position pp: Color, qq: Blink rr: Opening Title
	Title Set2	8x 01 04 73 2L mm nn pp qq rr ss tt uu vv ww FF	L: Line Number, mnpqrstuvw: Setting of characters (1 to 10)
	Title Set3	8x 01 04 73 3L mm nn pp qq rr ss tt uu vv ww FF	L: Line Number, mnpqrstuvw: Setting of characters (11 to 20)
	Title Clear	8x 01 04 74 1p FF	Title Setting clear (p: 0 to a, f= all lines)
	On	8x 01 04 74 2p FF	Title display On/Off (0 to a, f= all lines)
	Off	8x 01 04 74 3p FF	
CAM_Mute	On	8x 01 04 75 02 FF	Mute ON/OFF
	Off	8x 01 04 75 03 FF	
	On/Off	8x 01 04 75 10 FF	
CAM_PrivacyZone	SetMask	8x 01 04 76 mm nn 0r 0r 0s 0s FF	mm: Mask Settings nn 00: Modify, 01: New rr: W, ss:H
	Display	8x 01 04 77 pp pp pp pp FF	Mask Display ON/OFF pp pp pp pp: Mask Settings (0:OFF, 1:ON)
	SetMaskColor	8x 01 04 78 pp pp pp pp qq rr FF	pp pp pp pp: Mask Color Settings qq: Color Setting when 0 is selected rr: Color Setting when 1 is selected
	SetPanTiltAngle	8x 01 04 79 0p 0p 0p 0q 0q 0q FF	Pan/Tilt Angle Settings ppp: Pan qqq: Tilt
	SetPTZMask	8x 01 04 7B mm 0p 0p 0p 0q 0q 0q 0r 0r 0r 0r FF	Pan/Tilt/Zoom Settings for Mask ppp: Pan, qq: Tilt, rrrr: Zoom
	Non_InterlockMask	8x 01 04 6F mm 0p 0p 0q 0q 0r 0r 0s 0s FF	mm: Non_Interlock Mask Settings pp: X, q: Y, rr: W, ss: H
	GridOn	8x 01 04 7C 02 FF	Grid Display ON/OFF
	GridOff	8x 01 04 7C 03 FF	Grid/Center Line Display Off
	CenterLineOn	8x 01 04 7C 04 FF	Center Line Display On
CAM_KeyLock	Off	8x 01 04 17 00 FF	Camera Control Enable/Disable
	On	8x 01 04 17 02 FF	
CAM_IDWrite		8x 01 04 22 0p 0q 0r 0s FF	pqrs: Camera ID (=0000 to FFFF)
CAM_ExternalLock	INT	8x 01 04 55 00 FF	Internal mode
	Line Lock	8x 01 04 55 01 FF	Line Lock mode
CAM_VPhase	Stop	8x 01 04 05 00 FF	
	Up	8x 01 04 05 02 FF	
	Down	8x 01 04 05 03 FF	
	Up (Step)	8x 01 04 05 2p FF	p=step (1-7)
	Down (Step)	8x 01 04 05 3p FF	
	Reset	8x 01 04 05 40 FF	Restore Factory Settings
	Direct	8x 01 04 45 0p 0q 0r 0s FF	pqrs: V-Phase (0000~) (NTSC: 0000 to 20Chex, PAL: 0000 to 270hex)

## Command List (5/5)

Command Set	Command	Command Packet	Comments
CAM_MD	On	8x 01 04 1B 02 FF	Motion Detection On/Off
	Off	8x 01 04 1B 03 FF	
	Function Set	8x 01 04 1C 0m 0n 0p 0q 0r 0s FF	m: Display mode n: Detection Frame Set (0 to F) pq: Threshold Level (00 to FF) rs: Interval Time set (00 to FF)
	Window Set	8x 01 04 1D 0m 0p 0q 0r 0s FF	m: Select Detection Frame (0, 1, 2, 3) p: Start Horizontal Position (00 to 0B) q: Start Vertical Position (00 to 07) r: Stop Horizontal Position (01 to 0C) s: Stop Vertical Position (01 to 08)
	Alarm (Reply)	y0 07 04 1B 0p FF	p: Detection Frame Number
CAM_Continuous	On	8x 01 04 69 02 FF	ZoomPosition data Continuous Output On/Off
ZoomPosReply	Off	8x 01 04 69 03 FF	
	(Reply)	y0 07 04 69 0p 0p 0q 0q 0q 0q FF	pp: D-Zoom Position * 00: When Zoom Mode is Combine qqqq: Zoom Position
CAM_ReplyIntervalTimeSet		8x 01 04 6A 00 00 0p 0p FF	pp: Interval Time [Vertical timing]
CAM_RegisterValue		8x 01 04 24 mm 0p 0p FF	mm: Register No. (=00-7F) pp: Register Value (=00-7F)

## Inquiry Command List (1/3)

Inquiry Command	Command Packet	Inquiry Packet	Comments
CAM_PowerInq	8x 09 04 00 FF	y0 50 02 FF	On
		y0 50 03 FF	Off
CAM_ZoomPosInq	8x 09 04 47 FF	y0 50 0p 0q 0r 0s FF	pqrs: Zoom Position
CAM_DZoomModeInq	8x 09 04 06 FF	y0 50 02 FF	D-Zoom On
		y0 50 03 FF	D-Zoom Off
CAM_DZoomC/SModeInq	8x 09 04 36 FF	y0 50 00 FF	Combine Mode
		y0 50 01 FF	Separate Mode
CAM_DZoomPosInq	8x 09 04 46 FF	y0 50 00 00 0p 0q FF	pq: D-Zoom Position
CAM_FocusModeInq	8x 09 04 38 FF	y0 50 02 FF	Auto Focus
		y0 50 03 FF	Manual Focus
CAM_FocusPosInq	8x 09 04 48 FF	y0 50 0p 0q 0r 0s FF	pqrs: Focus Position
CAM_FocusNearLimitInq	8x 09 04 28 FF	y0 50 0p 0q 0r 0s FF	pqrs: Focus Near Limit Position
CAM_AFSensitivityInq	8x 09 04 58 FF	y0 50 02 FF	AF Sensitivity Normal
		y0 50 03 FF	AF Sensitivity Low
CAM_AFModeInq	8x 09 04 57 FF	y0 50 00 FF	Normal AF
		y0 50 01 FF	Interval AF
		y0 50 02 FF	Zoom Trigger AF
CAM_AFTimeSettingInq	8x 09 04 27 FF	y0 50 0p 0q 0r 0s FF	pq: Movement Time, rs: Interval
CAM_WBModeInq	8x 09 04 35 FF	y0 50 00 FF	Auto
		y0 50 01 FF	In Door
		y0 50 02 FF	Out Door
		y0 50 03 FF	One Push WB
		y0 50 04 FF	ATW
		y0 50 05 FF	Manual
CAM_RGainInq	8x 09 04 43 FF	y0 50 00 00 0p 0q FF	pq: R Gain
CAM_BGainInq	8x 09 04 44 FF	y0 50 00 00 0p 0q FF	pq: B Gain
CAM_AEModeInq	8x 09 04 39 FF	y0 50 00 FF	Full Auto
		y0 50 03 FF	Manual
		y0 50 0A FF	Shutter Priority
		y0 50 0B FF	Iris Priority
		y0 50 0D FF	Bright
CAM_SlowShutterModeInq	8x 09 04 5A FF	y0 50 02 FF	Auto
		y0 50 03 FF	Manual
CAM_ShutterPosInq	8x 09 04 4A FF	y0 50 00 00 0p 0q FF	pq: Shutter Position
CAM_IrisPosInq	8x 09 04 4B FF	y0 50 00 00 0p 0q FF	pq: Iris Position
CAM_GainPosInq	8x 09 04 4C FF	y0 50 00 00 0p 0q FF	pq: Gain Position
CAM_BrightPosInq	8x 09 04 4D FF	y0 50 00 00 0p 0q FF	pq: Bright Position
CAM_ExpCompModeInq	8x 09 04 3E FF	y0 50 02 FF	On
		y0 50 03 FF	Off
CAM_ExpCompPosInq	8x 09 04 4E FF	y0 50 00 00 0p 0q FF	pq: ExpComp Position
CAM_BacklightModeInq	8x 09 04 33 FF	y0 50 02 FF	On
		y0 50 03 FF	Off
CAM_AE_ResponseInq	8x 09 04 5D FF	y0 50 pp FF	pp: 01 to 20 (hex)
CAM_SpotAEModeInq	8x 09 04 59 FF	y0 50 02 FF	On
		y0 50 03 FF	Off
CAM_SpotAEPosInq	8x 09 04 29 FF	y0 50 0p 0q 0r 0s FF	pq: X position, rs: Y position
CAM_WDModeInq	8x 09 04 3D FF	y0 50 02 FF	On Wide-D
		y0 50 03 FF	Off

## Inquiry Command List (2/3)

Inquiry Command	Command Packet	Inquiry Packet	Comments
CAM_ApertureInq	8x 09 04 42 FF	y0 50 00 00 0p 0q FF	pq: Aperture Gain
CAM_HRModeInq	8x 09 04 52 FF	y0 50 02 FF	On Hi-Resolution
		y0 50 03 FF	Off
CAM_LR_ReverseModeInq	8x 09 04 61 FF	y0 50 02 FF	On
		y0 50 03 FF	Off
CAM_FreezeModeInq	8x 09 04 62 FF	y0 50 02 FF	On
		y0 50 03 FF	Off
CAM_PictureEffectModeInq	8x 09 04 63 FF	y0 50 00 FF	Off
		y0 50 02 FF	Neg.Art
		y0 50 04 FF	B&W
CAM_PictureFlipModeInq	8x 09 04 66 FF	y0 50 02 FF	On
		y0 50 03 FF	Off
CAM_ICRModeInq	8x 09 04 01 FF	y0 50 02 FF	On
		y0 50 03 FF	Off
CAM_AutoICRModeInq	8x 09 04 51 FF	y0 50 02 FF	On
		y0 50 03 FF	Off
CAM_AutoICRThresholdInq	8x 09 04 21 FF	y0 50 00 00 0p 0q FF	pq: ICR ON → OFF Threshold Level
CAM_MemoryInq	8x 09 04 3F FF	y0 50 pp FF	pp: Last Recall Memory No.
CAM_MemSaveInq	8x 09 04 23 0X FF	y0 50 0p 0p 0q 0q FF	X: 00 to 07 (Address) ppqq: 0x0000 to 0xFFFF (Data)
CAM_DisplayModeInq	8x 09 04 15 FF (8x 09 06 06 FF)	y0 50 02 FF	On
		y0 50 03 FF	Off
CAM_TitleDisplayModeInq	8x 09 04 74 FF	y0 50 02 FF	On
		y0 50 03 FF	Off
CAM_MuteModeInq	8x 09 04 75 FF	y0 50 02 FF	On
		y0 50 03 FF	Off
CAM_PrivacyDisplayInq	8x 09 04 77 FF	y0 50 pp pp pp pp FF	pp pp pp pp: Mask Display (0:OFF, 1:ON)
CAM_PrivacyPanTiltInq	8x 09 04 79 FF	y0 50 0p 0p 0p 0q 0q 0q FF	ppp: Pan qqq: Tilt
CAM_PrivacyPTZInq	8x 09 04 7B mm FF	y0 50 0p 0p 0p 0q 0q 0r 0r 0r 0r FF	mm: Mask Settings ppp: Pan qqq: Tilt rrr: Zoom
CAM_PrivacyMonitorInq	8x 09 04 6F FF	y0 50 pp pp pp pp FF	pp pp pp pp: Mask is displayed now.
CAM_KeyLockInq	8x 09 04 17 FF	y0 50 00 FF	Off
		y0 50 02 FF	On
CAM_IDInq	8x 09 04 22 FF	y0 50 0p 0q 0r 0s FF	pqrs: Camera ID
CAM_ExternalLockModeInq	8x 09 04 55 FF	y0 50 00 FF	Internal Mode
		y0 50 01 FF	Line Lock Mode
CAM_VPhaseSetInq	8x 09 04 25 FF	y0 50 00 FF	0 degree
		y0 50 01 FF	180 degree
CAM_VPhasePosInq	8x 09 04 45 FF	y0 50 0p 0q 0r 0s FF	pqrs: V-Phase Position
CAM_VersionInq	8x 09 00 02 FF	y0 50 00 20 mn pq rs tu vw FF	mnpq: Model Code (04xx) rstu: ROM version vw: Socket Number (=02)



## Inquiry Command List (3/3)

Inquiry Command	Command Packet	Inquiry Packet	Comments
CAM_MDModeInq	8x 09 04 1B FF	y0 50 02 FF	On
		y0 50 03 FF	Off
CAM_MDFunctionInq	8x 09 04 1C FF	y0 50 0m 0n 0p 0q FF	m: Display mode n: Detection Frame Set (0 to F) pq: Threshold Level (0 to FF) rs: Interval Time set (0 to FF)
CAM_MDWindowInq	8x 09 04 1D 0m FF	y0 50 0p 0q 0r 0s FF	m: Select Detection Frame (0, 1, 2, 3) p: Start Horizontal Position (00 to 0B) q: Start Vertical Position (00 to 07) r: Stop Horizontal Position (01 to 0C) s: Stop Vertical Position (01 to 08)
CAM_ContinuousZoomPos ReplyModeInq	8x 09 04 69 FF	y0 50 02 FF	On
		y0 50 03 FF	Off
CAM_ReplyIntervalTimeInq	8x 09 04 6A FF	y0 50 00 00 0p 0p FF	pp: Interval Time
CAM_RegisterValueInq	8x 09 04 24 mm FF	y0 50 0p 0p ff	mm: Register No. (00 to 7F) pp: Register Value (00 to FF)

# Block Inquiry Command List

## Lens Control System Inquiry Commands ..... Command Packet 8x 09 7E 7E 00 FF

Byte	Bit	Comments	Byte	Bit	Comments	Byte	Bit	Comments	
0	7	Destination Address	6	7	0	12	7	0	
	6			0	6		0		
	5			0	5		0		
	4			0	4		0		
	3	Source Address		3	Focus Near Limit (H)		3	0	
	2			2			0		
	1			1			0		
	0			0			0		
1	7	0 Completion Message (50h)	7	7	0		13	7	0
	6	1		6	0			6	0
	5	0		5	0			5	DZoomMode 0: Combine 1: Separate
	4	1		4	0			4	0: Normal 1: Interval
	3	0		3	Focus Near Limit (L)	3		2: Zoom Trigger	
	2	0				2		AF Sensitivity 0: Slow 1: Normal	
	1	0				1		Digital Zoom 1:On 0:Off	
	0	0				0		Focus Mode 0:Manual 1:Auto	
2	7	0	8	7	0	14		7	0
	6	0		6	0			6	0
	5	0		5	0			5	0
	4	0		4	0			4	0
	3	Zoom Position (HH)		3	Focus Position (HH)			3	Low Contrast Detection 1: Yes 0: No
	2			2			2	Camera Memory Recall 1: Executing 0: Stopped	
	1			1			1	Focus Command 1: Executing 0: Stopped	
	0			0			0	Zoom Command 1: Executing 0: Stopped	
3	7	0	9	7	0		15	7	1 Terminator (FFh)
	6	0		6	0			6	1
	5	0		5	0			5	1
	4	0		4	0			4	1
	3	Zoom Position (HL)		3	Focus Position (HL)			3	1
	2			2				2	1
	1			1		1		1	
	0			0		0		1	
4	7	0	10	7	0	0		0	1
	6	0		6	0			6	1
	5	0		5	0			5	1
	4	0		4	0			4	1
	3	Zoom Position (LH)		3	Focus Position (LH)			3	1
	2			2				2	1
	1			1				1	1
	0			0			0	1	
5	7	0	11	7	0	0	0	1	
	6	0		6	0		6	1	
	5	0		5	0		5	1	
	4	0		4	0		4	1	
	3	Zoom Position (LL)		3	Focus Position (LL)		3	1	
	2			2			2	1	
	1			1			1	1	
	0			0			0	1	

**Camera Control System Inquiry Commands ..... Command Packet 8x 09 7E 7E 01 FF**

Byte	Bit	Comments	Byte	Bit	Comments	Byte	Bit	Comments			
0	7	Destination Address	6	7	0	12	7	0			
	6			0	6		0				
	5			0	5		0				
	4			0	4		0				
	3	Source Address		3	0		3	Gain Position			
	2			WB Mode							
	1				Aperture Gain						
	0						Exposure Mode				
1	7	0 Completion Message (50h)	7					7	0	13	7
	6	1		6				0	6		0
	5	0		5	0			5	0		
	4	1		4	0		4	Bright Position			
	3	0		3	Exposure Comp. Position						
	2	0		2		Exposure Mode					
	1	0		1			Exposure Comp. Position				
	0	0		0				Exposure Mode			
2	7	0	8	7	0				14		7
	6	0		6	0	6					0
	5	0		5	0	5	0				
	4	0		4	Exposure Mode	4	0				
	3	R Gain (H)		3		Exposure Comp. Position					
	2			Exposure Mode							
	1						Exposure Comp. Position				
	0				Exposure Mode						
3	7	0	9			7		0		15	7
	6	0		6		0		6			1
	5	0		5		High-Resolution 1: On 0: Off	5	1			
	4	0		4	Wide-D 1: On 0: Off	4	1				
	3	R Gain (L)		3	Spot AE 1: On 0: Off	3	1				
	2			Exposure Mode	2	Back Light 1:On 0:Off	2	1			
	1				Exposure Comp. Position	1	Exposure Comp. 1:On 0:Off	1	1		
	0					Exposure Mode	0	Slow Shutter 1:Auto 0:Manual	0		1
4	7	0	10				7	0	11		7
	6	0		6			0	6			0
	5	0		5	0		5	0			
	4	0		4	Shutter Position	4	Iris Position				
	3	B Gain (H)		3		Iris Position					
	2			Iris Position							
	1							Iris Position			
	0				Iris Position						
5	7	0	11			7	0			11	7
	6	0		6		0	6				0
	5	0		5		0	5	0			
	4	0		4	Iris Position	4	Iris Position				
	3	B Gain (L)		3		Iris Position					
	2			Iris Position							
	1							Iris Position			
	0				Iris Position						

**Other Inquiry Commands ..... Command Packet 8x 09 7E 7E 02 FF**

Byte	Bit	Comments	Byte	Bit	Comments	Byte	Bit	Comments	
0	7	Destination Address	6	7	0	12	7	0	
	6			0	6		0		
	5			0	5		External Lock 1: Provided 0: Not provided		
	4			0	4		Memory 1: Provided 0: Not provided		
	3	Source Address		3	0		3	Clock 1: Provided 0: Not provided	
	2			0	2		ICR 1: Provided 0: Not provided		
	1			0	1		0		
	0			0	0		System 1:PAL 0:NTSC		
1	7	0 Completion Message (50h)	7	7	0		13	7	0
	6	1		6	0			6	0
	5	0		5	0			5	0
	4	1		4	0			4	External Lock Mode 1: Line Lock 0: Internal
	3	0		3	0	3		V-Phase (H)	
	2	0		2	0	2			
	1	0		1	0	1			
	0	0		0	0	0			
2	7	0	8	7	0	14		7	0
	6	0		6	0			6	0
	5	0		5	0			5	V-Phase (L)
	4	0		4	0			4	
	3	0		3	Camera ID (HH)		3		
	2	Auto ICR 1: On 0: Off		2					
	1	Key Lock 1: On 0: Off		1					
	0	Power 1:On 0:Off		0					
3	7	0	9	7	0		15	7	1 Terminator (FFh)
	6	0		6	0			6	1
	5	0		5	0			5	1
	4	ICR 1: On 0: Off		4	0			4	1
	3	Freeze 1:On 0:Off		3	Camera ID (HL)	3			
	2	LR Reverse 1:On 0:Off		2					
	1	0		1					
	0	0		0					
4	7	0	10	7	0	15		6	1
	6	0		6	0			5	1
	5	Privacy Zone 1: On 0: Off		5	0			4	1
	4	Mute 1: On 0: Off		4	0			3	1
	3	Title Display 1: On 0: Off		3	Camera ID (LH)		2	1	
	2	Display 1: On 0: Off		2					
	1	0		1					
	0	0		0					
5	7	0	11	7	0		15	1	1
	6	0		6	0			0	1
	5	0		5	0			3	Camera ID (LL)
	4	0		4	0			2	
	3	0		3					
	2	Picture Effect Mode		2					
	1			1					
	0			0					

**Enlargement Function Query Command ..... Command Packet 8x 09 7E 7E 03 FF**

Byte	Bit	Comments	Byte	Bit	Comments	Byte	Bit	Comments		
0	7	Destination Address	6	7	0	11	7	0		
	6			0	6		0			
	5			0	5		0			
	4			0	4		0			
	3	Source Address		3	AF Interval Time (H)		3	0		
	2			2			Advanced Privacy (1: Provided, 0: Not provided)			
	1			1			Alarm (1: Provided, 0: Not provided)			
	0			0			Picture flip (1: Provided, 0: Not provided)			
1	7	0 Completion Message (50h)	7	7	0		12	7	0	
	6	1		6	0			6	0	
	5	0		5	0			5	AE Response	
	4	1		4	0	4				
	3	0		3	AF Interval Time (L)	3				
	2	0		2						
	1	0		1						
	0	0		0						
2	7	0	8	7	0	13		7	0	
	6	0		6	0			6	0	
	5	0		5	0			5	0	
	4	0		4	0		4	0		
	3	Digital Zoom Position (H)		3	SpotAE Position (X)		3	AE Response		
	2			2						
	1			1						
	0			0						
3	7	0	9	7	0		14		7	0
	6	0		6	0				6	0
	5	0		5	0			5	0	
	4	0		4	0	4		0		
	3	Digital Zoom Position (L)		3	SpotAE Position (Y)	3		0		
	2			2						
	1			1						
	0			0						
4	7	0	10	7	0	15		7	1 Terminator (FFh)	
	6	0		6	0			6	1	
	5	0		5	0			5	1	
	4	0		4	0		4	1		
	3	AF Activation Time (H)		3	0		3	1		
	2			2	MD (1: On, 0: Off)					
	1			1	Alarm (1: On, 0: Off)					
	0			0	Picture flip (1: On, 0: Off)					
5	7	0	10	7	0		15	2	1	
	6	0		6	0			1	1	
	5	0		5	0			0	1	
	4	0		4	0					
	3	AF Activation Time (L)		3	0					
	2			2						
	1			1						
	0			0						

# VISCA Command Setting Values

## Exposure control (1/2)

		NTSC (s)	PAL (s)
Shutter Speed	15	1/10000	1/10000
	14	1/6000	1/6000
	13	1/4000	1/3500
	12	1/3000	1/2500
	11	1/2000	1/1750
	10	1/1500	1/1250
	0F	1/1000	1/1000
	0E	1/725	1/600
	0D	1/500	1/425
	0C	1/350	1/300
	0B	1/250	1/215
	0A	1/180	1/150
	09	1/125	1/120
	08	1/100	1/100
	07	1/90	1/75
	06	1/60	1/50
	05	1/30	1/25
	04	1/15	1/12
	03	1/8	1/6
	02	1/4	1/3
01	1/2	1/2	
00	1/1	1/1	
Iris	11	F1.6	
	10	F2	
	0F	F2.4	
	0E	F2.8	
	0D	F3.4	
	0C	F4	
	0B	F4.8	
	0A	F5.6	
	09	F6.8	
	08	F8	
	07	F9.6	
	06	F11	
	05	F14	
	04	F16	
	03	F19	
	02	F22	
01	F28		
00	CLOSE		

Gain	0F	28 dB
	0E	26 dB
	0D	24 dB
	0C	22 dB
	0B	20 dB
	0A	18 dB
	09	16 dB
	08	14 dB
	07	12 dB
	06	10 dB
	05	8 dB
	04	6 dB
	03	4 dB
	02	+2 dB
	01	0
	00	-3 dB

## Exposure control (2/2)

		IRIS	GAIN
Bright	1F	F1.6	28 dB
	1E	F1.6	26 dB
	1D	F1.6	24 dB
	1C	F1.6	22 dB
	1B	F1.6	20 dB
	1A	F1.6	18 dB
	19	F1.6	16 dB
	18	F1.6	14 dB
	17	F1.6	12 dB
	16	F1.6	10 dB
	15	F1.6	8 dB
	14	F1.6	6 dB
	13	F1.6	4 dB
	12	F1.6	2 dB
	11	F1.6	0
	10	F2	0
	0F	F2.4	0
	0E	F2.8	0
	0D	F3.4	0
	0C	F4	0
	0B	F4.8	0
	0A	F5.6	0
	09	F6.8	0
	08	F8	0
	07	F9.6	0
	06	F11	0
	05	F14	0
	04	F16	0
	03	F19	0
	02	F22	0
01	F28	0	
00	CLOSE	0	
Exposure Comp.	0E	7	10.5 dB
	0D	6	9 dB
	0C	5	7.5 dB
	0B	4	6 dB
	0A	3	4.5 dB
	09	2	3 dB
	08	1	1.5 dB
	07	0	0 dB
	06	-1	-1.5 dB
	05	-2	-3 dB
	04	-3	-4.5 dB
	03	-4	-6 dB
	02	-5	-7.5 dB
	01	-6	-9 dB
	00	-7	-10.5 dB

Zoom Ratio and Zoom Position  
(for reference)

Zoom Ratio ×36 Lens	Optical Zoom Positon Data
×1	0000
×2	166F
×3	1FF0
×4	257D
×5	2940
×6	2C02
×7	2E2B
×8	2FEE
×9	316A
×10	32B2
×11	33D4
×12	34D9
×13	35C8
×14	36A4
×15	3773
×16	3836
×17	38F0
×18	39A0
×19	3A49
×20	3AE8
×21	3B7F
×22	3C0C
×23	3C8E
×24	3D06
×25	3D73
×26	3DD4
×27	3E2C
×28	3E7C
×29	3EC2
×30	3F00
×31	3F38
×32	3F68
×33	3F94
×34	3FBD
×35	3FDF
×36	4000

### Digital Zoom Combine mode

#### X12-NTSC/PAL

Digital Zoom Ratio	Digital Zoom Position Data
×1	4000
×2	6000
×3	6A80
×4	7000
×5	7300
×6	7540
×7	76C0
×8	7800
×9	78C0
×10	7980
×11	7A00
×12	7AC0

### Digital Zoom Separate mode

#### X12-NTSC/PAL

Digital Zoom Ratio	Digital Zoom Position Data
×1	00
×2	80
×3	AA
×4	C0
×5	CC
×6	D5
×7	DB
×8	E0
×9	E3
×10	E6
×11	E8
×12	EB

### Title setting

Line number	00 to 0A	
H-position	00 to 17	
Blink	00: Dose not blink	
	01: Blinks	
Color	00	White
	01	Yellow
	02	Violet
	03	Red
	04	Cyan
	05	Green
	06	Blue

00	01	02	03	04	05	06	07
A	B	C	D	E	F	G	H
08	09	0a	0b	0c	0d	0e	0f
I	J	K	L	M	N	O	P
10	11	12	13	14	15	16	17
Q	R	S	T	U	V	W	X
18	19	1a	1b	1c	1d	1e	1f
Y	Z	&		?	!	1	2
20	21	22	23	24	25	26	27
3	4	5	6	7	8	9	0
28	29	2a	2b	2c	2d	2e	2f
À	È	Ì	Ò	Ù	Á	É	Í
30	31	32	33	34	35	36	37
Ó	Ú	Â	Ê	Ô	Æ	Œ	Ä
38	39	3a	3b	3c	3d	3e	3f
Û	Ñ	Ç	ß	Ä	Ï	Ö	Ü
40	41	42	43	44	45	46	47
Å	\$	₣	¥	DM	£	ı	ı
48	49	4a	4b	4c	4d	4e	4f
ø	“	:	‘	.	,	/	-

### Lens control

Zoom Position	0000 to 4000 to 7AC0 Wide end    Optical    Digital Tele end    Tele end	
Focus Position	1000 to C000 Far end      Near end	
Focus Near Limit	1000: Over Inf 2000: 20 m 3000: 10 m 4000: 5 m 5000: 3 m 6000: 2 m 7000: 1.5 m 8000: 32 cm 9000: 9.5 cm A000: 4.5 cm B000: 2 cm C000: 1 cm	As the distance on the left will differ due to temperature characteristics, etc., use as approximate values. * The lower 1 byte is fixed at 00.

### Register Setting

	Register No.	Value	
VISCA	00	00	9600 bps
Baud Rate		01	19200 bps
		02	38400 bps
OSD Language	60	00	English
		03	Chinese



---

**Others**

AF Active Time*	00	to	FF
AF Interval Time*	00	to	FF
Spot AE X position	00	to	0F
Spot AE Y position	00	to	0F
R Gain	00	to	FF
B Gain	00	to	FF
Aperture Level	00	to	0F
V-Phase	00	to	020C (NTSC) 0270 (PAL)
AE Response	01	to	20
AutoICR ON → OFF Threshold Level	00	to	1C
MD Threshold Level	00	to	FF
MD Interval Time*	00	to	FF
MD Set Horizontal Position	00	to	0C
MD Set Vertical Position	00	to	08

\* Unit: One second

# Specifications

Picture elements	FCB-EX1010: Approx. 380K pixels FCB-EX1010P: Approx. 440K pixels	Electronic shutter speed	FCB-EX1010: 1/4 to 1/10000 sec. (20 steps) FCB-EX1010P: 1/3 to 1/10000 sec. (20 steps)
Horizontal resolution	NTSC: 530 TV lines (WIDE end) PAL: 530 TV lines (WIDE end)	White balance	AUTO, ATW, Indoor, Outdoor, One Push WB, Manual WB
Lens	36× zoom F= 3.4 mm (WIDE) to 122.4 mm (TELE), F1.6 to F4.5 Zoom movement speed (NTSC) Optical WIDE/Optical TELE 4.0 sec Optical WIDE/Digital TELE 6.0 sec Digital WIDE/Digital TELE 2.1 sec (PAL) Optical WIDE/Optical TELE 4.0 sec Optical WIDE/Digital TELE 6.2 sec Digital WIDE/Digital TELE 2.3 sec Focus Movement time ∞ to Near 1.0 sec	Gain	Auto/Manual (-3 to 28 dB, 16 steps)
Digital zoom	12× (432× with optical zoom)	Wide dynamic	ON/OFF
Angle of view (H)	Approx. 57.8 degree (WIDE end) to Approx. 1.7 degree (TELE end)	Aperture control	16 steps
Min. working distance	320 mm (WIDE end), 1500 mm (TELE end)	Preset	6-POSITIONS
Sync system	Internal/External (V-Lock)	Serial interface	VISCA protocol (TTL/CMOS) 9.6 Kbps, 19.2 Kbps, 38.4 Kbps, Stop bit, 1/2 bit
Min. illumination	1.4 lux/1/60 sec (NTSC), 1/50 sec (PAL) (Typical value) 0.1 lux/1/4 sec (NTSC), 1/3 sec (PAL) (Typical value) ICR-ON Mode 0.01 lux/1/4 sec (NTSC), 1/3 sec (PAL)	Video Output	VBS: 1.0 Vp-p (Sync negative), Y/C Output
Recommended illumination	100 to 100,000 lux	Storage temperature/Humidity	-20 to 60 °C (-4 to 140 °F)/20 to 95 %
S/N ratio	50 dB (Weight ON)	Operating temperature/Humidity	0 to 50 °C (32 to 122 °F)/20 to 80 %
Back light compensation	ON/OFF	Power requirements/Power consumption	6 to 12 V DC/2.6 W (4.9 W)
		Weight	230 g (8.1 oz.)
		Dimensions	50.0 × 57.5 × 87.9 mm (2 × 2 <sup>3</sup> / <sub>8</sub> × 3 <sup>1</sup> / <sub>2</sub> in.) (w/h/d)

Design and specifications are subject to change without notice.

**Dimensions**

**Front**

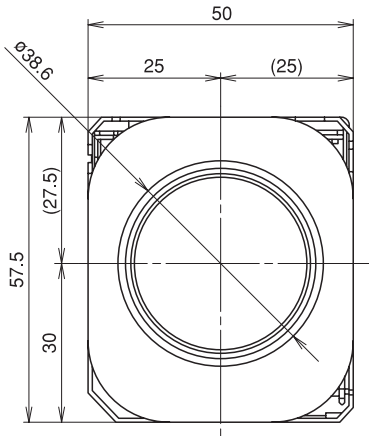

**Left side**

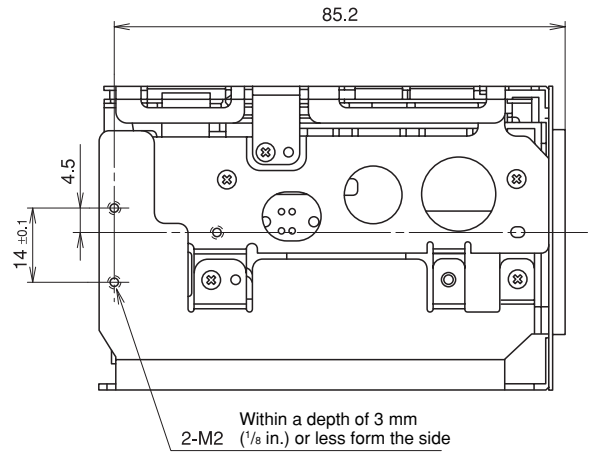

**Top**

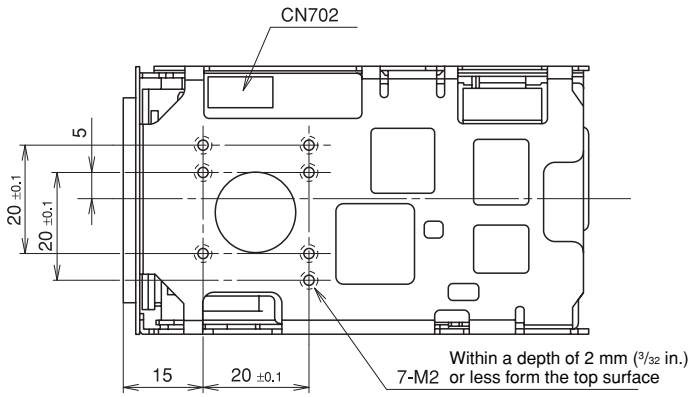

**Right side**

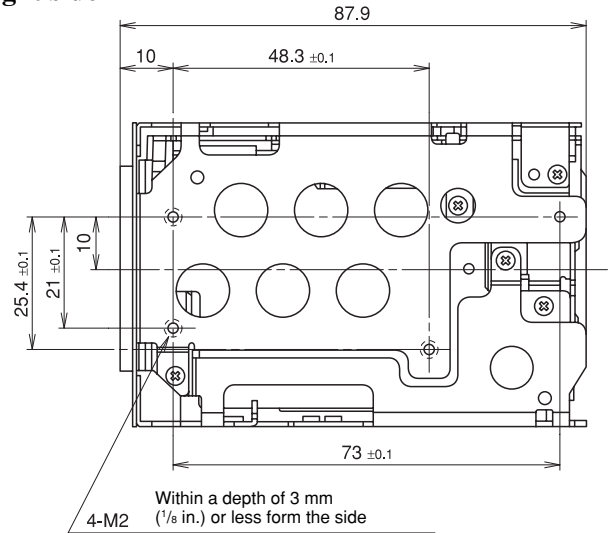

**Bottom**

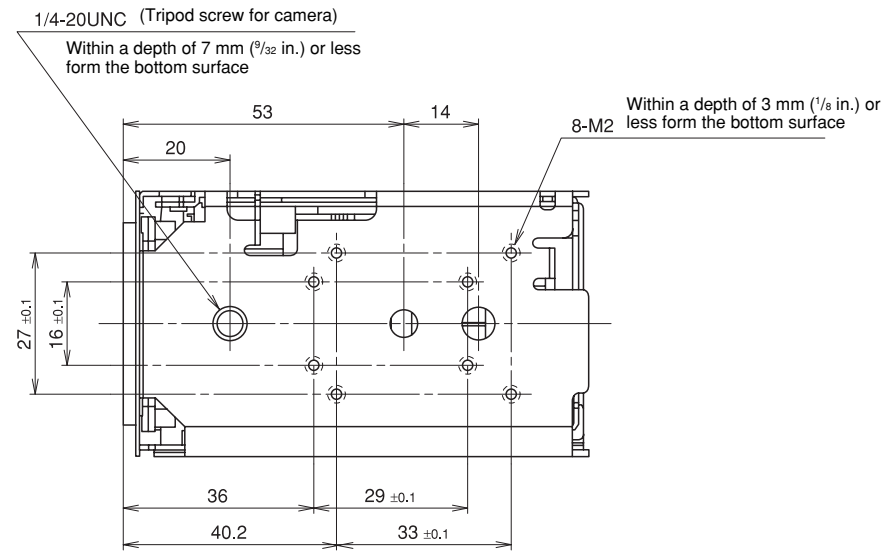

**Back**

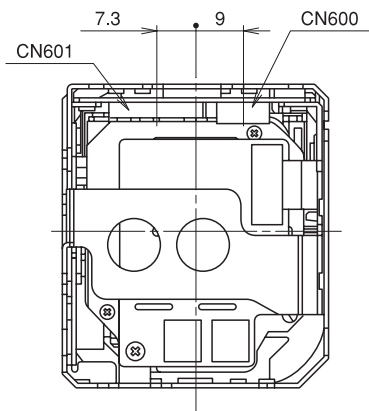

Unit: mm (inches)

**Pin assignment**

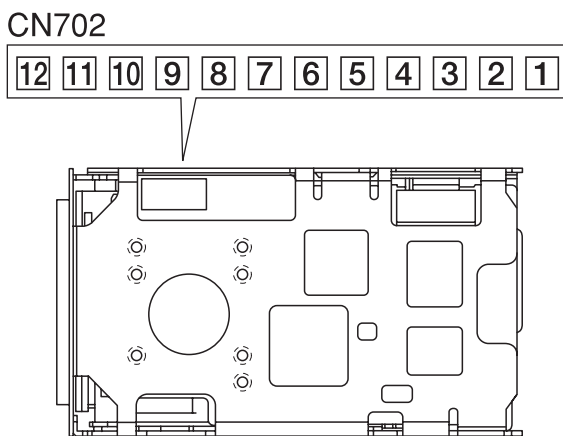
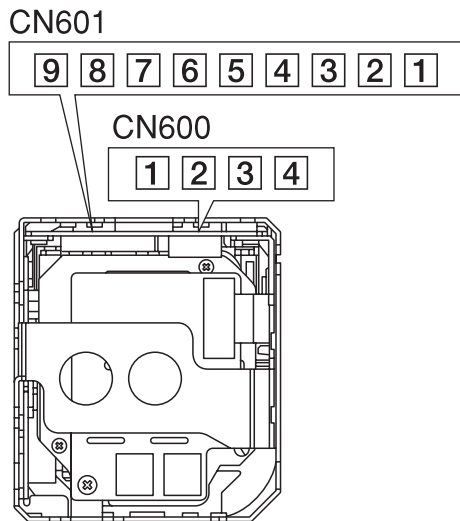

**CN601**  
KYOCERA ELCO Co. 00 6200 509 130 000+

Pin No.	Name	Level
1	RxD	CMOS 5V (low: max 0.8V, high: min 2.0V) Read Data
2	TxD	CMOS 5V (low: max 0.1V, high: min 4.4V) Send Data
3	GND (for RxD&TxD)	
4	DC IN	9.0V±3V
5	GND (for DC IN)	
6	VBS OUT	1.0V±0.2V
7	GND (for VBS OUT)	
8	V LOCK PULSE	External VD-Lock Pulse (EX.FV: Negative, 3Vp-p 50% duty)
9	GND (VL PULSE)	

**CN600**  
J.S.T. Mfg Co. S4B-ZR-SM4A-TF(LF)

Pin No.	Name	Level
1	Y_Out	
2	GND (for Y signal)	
3	C_Out	
4	GND (for C signal)	

**CN702**  
KYOCERA ELCO Co. 086222012101848+

Pin No.	Name	Level
1	GND	
2	GND	
3	KEY AD0	
4	KEY AD1	
5	KEY AD2	
6	KEY AD3	
7	KEY AD4	
8	KEY AD5	
9	KEY AD6	
10	KEY AD7	
11	NC	
12	Strobe	

**Strobe signal specifications**

